

# Section Eleven

## Miscellaneous

	Page Number	
<i>Valance Assembly - High Hose</i>		T
Serial No. 069-20026 & Below .....	11-2	C
Serial No. 069-20027 & Above .....	11-4, 11-5	S
<i>Light Box Assembly</i>		
Model H3, H4 & H6 .....	11-6, 11-7	
<i>Reel Channel Assembly</i>		D
Model 324AR-H & 426AR-H.....	11-8, 11-9	I
<i>Sight Glass Assembly</i>		S
.....	11-10	P
<i>Valance Assembly - Lighted</i>		E
.....	11-12, 11-13, 11-14	N
		S
		E
		R

VALANCE ASSEMBLY (TCS HIGH HOSE)

(SERIAL NO. 069-20026 &amp; BELOW)

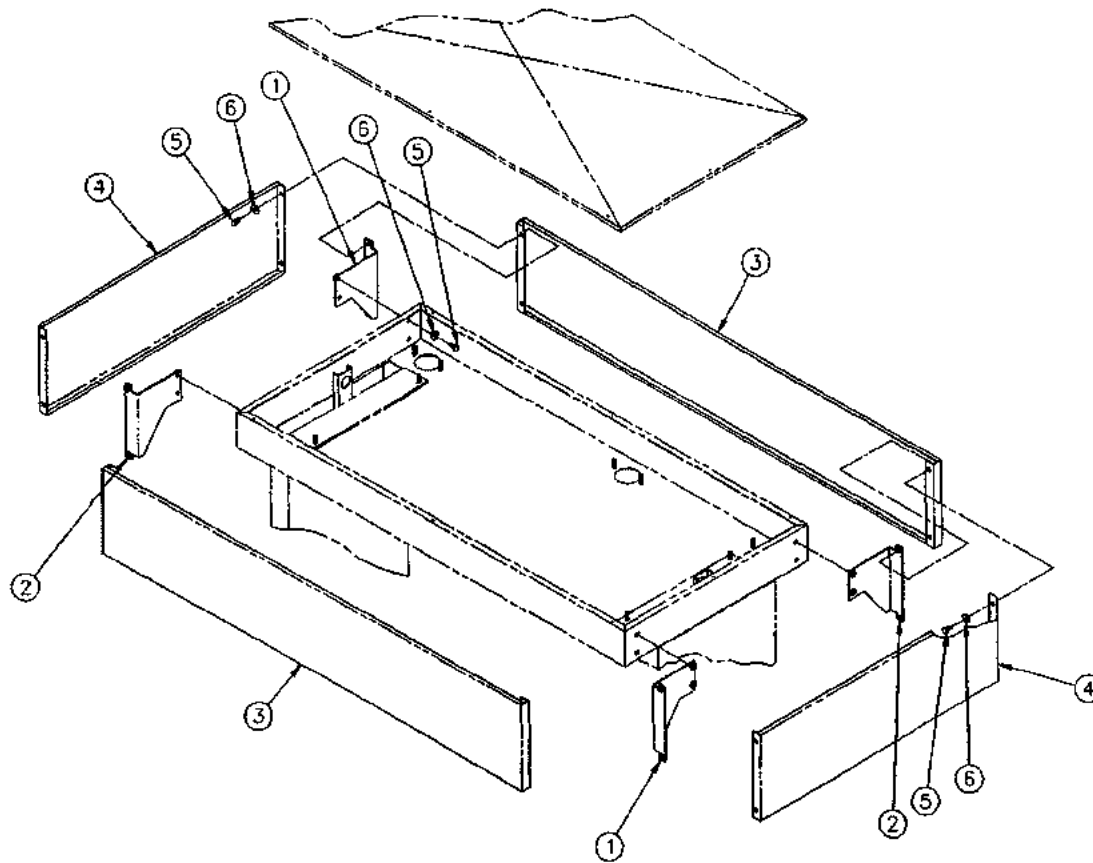

Item No.	Part No.	Name Of Part
1	318237-1	Right Support Weld Assy.
2	318237-2	Left Support Weld Assy.
3	1-419743	Painted Side Panel (30")
	2-419743	Stainless Steel Side Panel (30")
	1-419239	Painted Side Panel (45")
	2-419239	Stainless Steel Side Panel (45")
	1-419756	Painted Side Panel (60")
	2-419756	Stainless Steel Side Panel (60")
4	1-419240	Painted End Panel (45" & 60")
	2-419240	Stainless Steel End Panel (45" & 60")
	1-419815	Painted End Panel (30")
	2-419815	Stainless Steel End Panel (30")
5	32-50361	5/16-18 X 5/8 Lg. Hex Hd. Cap Screw
6	03-50611	5/16 Plate Washer



**VALANCE ASSEMBLY (TCS HIGH HOSE)**  
(SERIAL NO. 069-20027 & ABOVE)

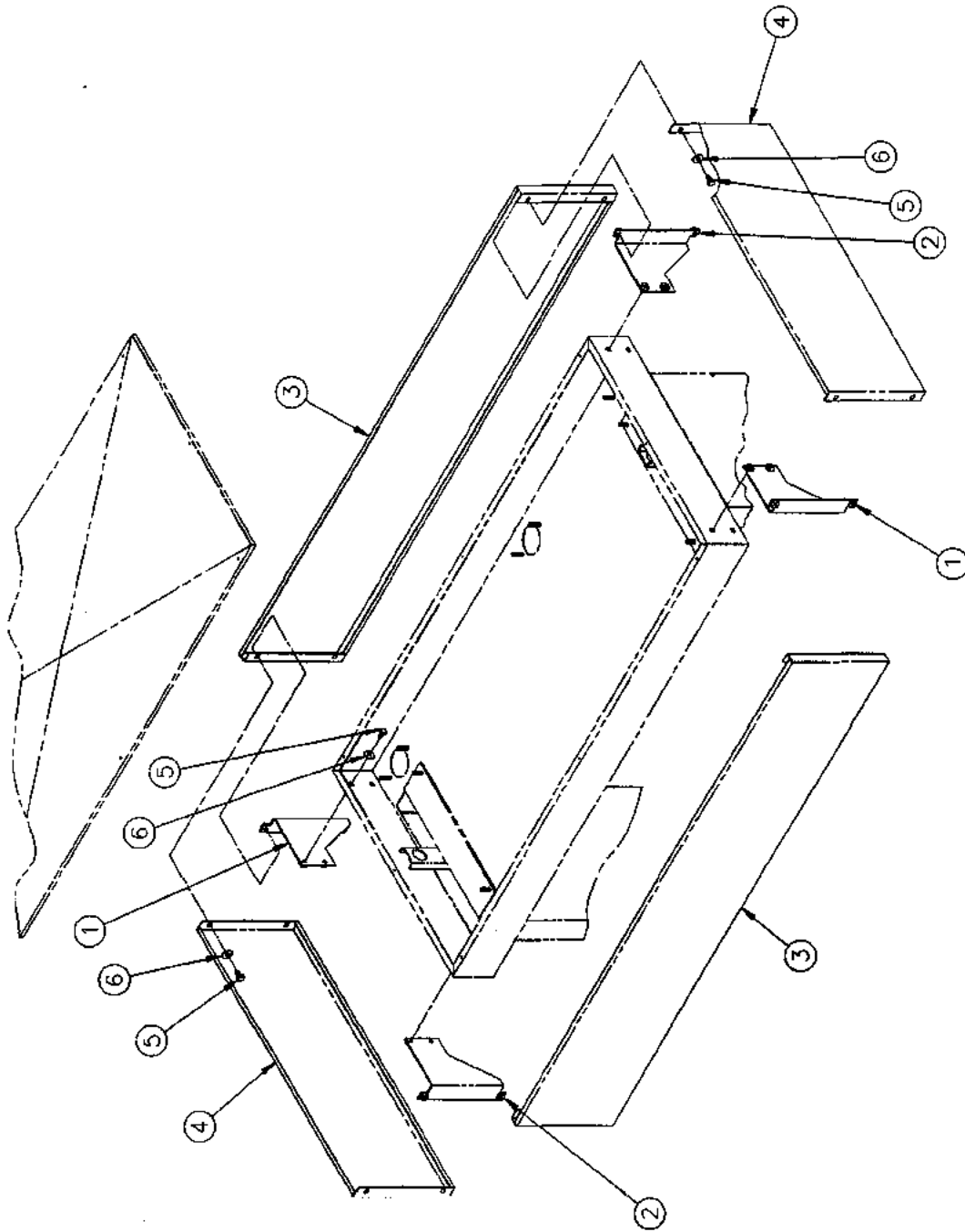

3-741420

**VALANCE ASSEMBLY (TCS HIGH HOSE)**  
**(SERIAL NO. 069-20027 & ABOVE)**

ITEM NO.	PART NO.	DESCRIPTION
1		<u>Right Support Weld Assembly</u>
	318348-1	All Models Except Listed Below
	319572-2	45" MaxVac
	319662-2	30" MaxVac
2		<u>Left Support Weld Assembly</u>
	318348-2	All Models Except Listed Below
	319572-1	45" MaxVac
	319662-1	30" MaxVac
3		<u>Side Panel</u>
	1-419239	45" (Painted)
	2-419239	45" (Stainless Steel)
	1-419743	30" (Painted)
	2-419743	30" (Stainless Steel)
	1-419756	60" (Painted)
	2-419756	60" (Stainless Steel)
4		<u>End Panel</u>
	1-419815	Painted
	2-419815	Stainless Steel
5		<u>5/16-18 x 3/4" Long Hex Head Cap Screw</u>
	33-50361	All Models Except MaxVac
	1-230958	MaxVac
6	03-50611	5/16" Plate Washer

**3-741420**

# LIGHT BOX ASSEMBLY

MODEL H3, H4 & H6

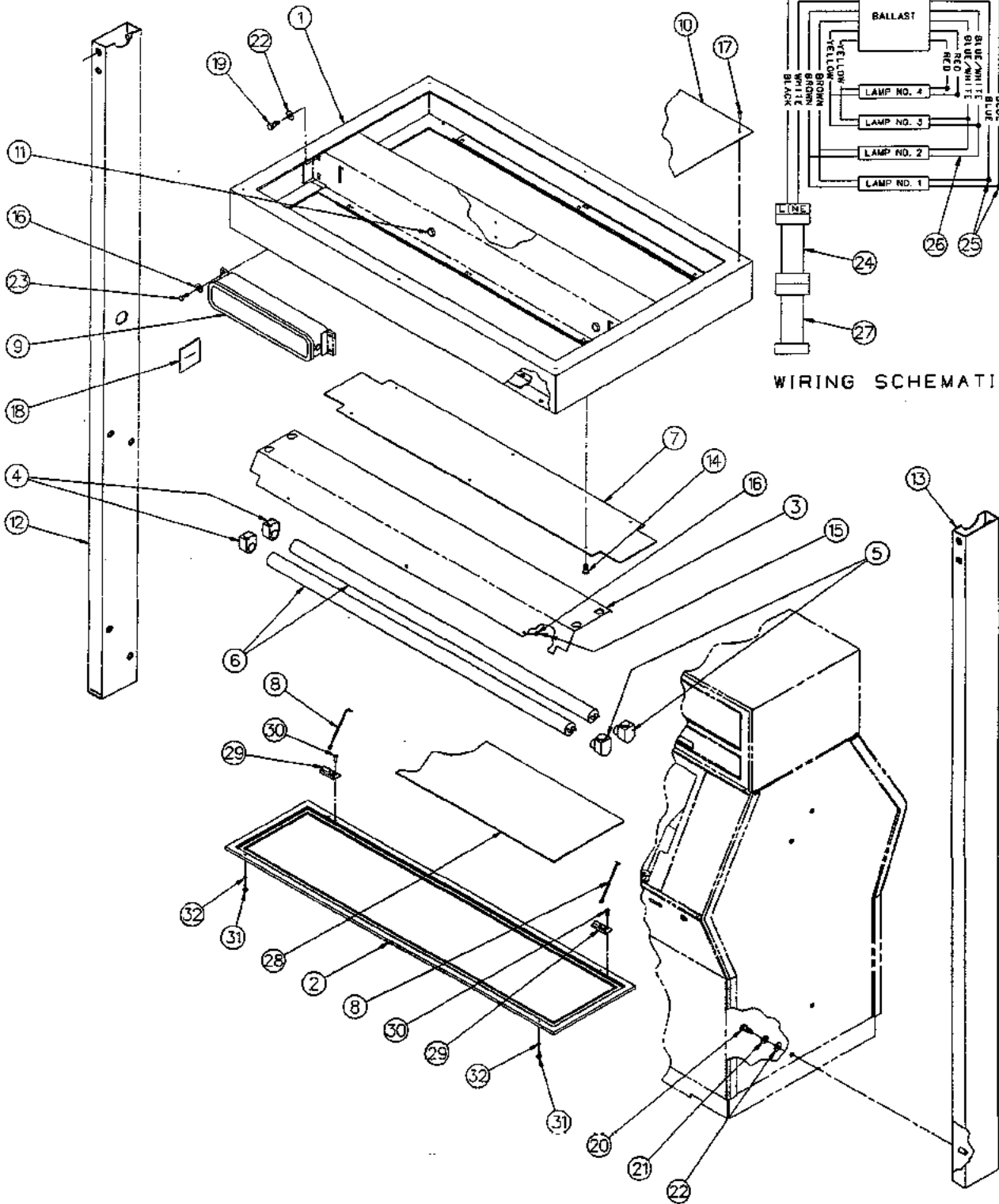

1-741340

# LIGHT BOX ASSEMBLY - Model H3, H4, & H6

ITEM NO.	PART NO.	DESCRIPTION	ITEM NO.	PART NO.	DESCRIPTION
1	<u>Channel Weld Assemblies</u>		11	3-225460	Bushing
	419034-4	H3	12	419044-3	Column Weld & Insert Assembly
	419034-5	H4	13	419044-4	Column Weld & Insert Assembly
	419034-6	H6	14	291-50012	#10-32 X 1/2 Large Flat Head Machine Screw
2	<u>Light Frame Weld Assemblies</u>		15	35-50451	#10-24 Round Head Threaded Cutting Screw
	418798-4	H3	16	05-50762	#10 Shakeproof Lockwasher
	418798-5	H4	17	1-131934	Waterproof Rivet
	418798-6	H6	18	1-229283	Column Seal
3	<u>Reflectors</u>		19	64-50361	3/8-16 X 7/8 Large Hex Head Cap Screw
	2-418778	H4	20	65-50361	3/8-16 X 1" Large Hex Head Cap Screw
	2-419010	H3	21	09-50621	3/8 Plain Washer
	2-419011	H6	22	15-50641	3/8 Split Lockwasher
4	1-226859	Lampholder	23	295-50001	#10-32 X 3/4 Large Round Head Machine Screw
5	2-226859	Lampholder	24	318161-1	Wire Harness Assembly
6	<u>Flourescent Lamps</u>		25	1-127473	Wire Connector
	6-226895	H4	26	<u>#18 White Conductors</u>	
	7-226895	H6		018-548904-09	H3
	8-226895	H3		036-548904-09	H4
7	<u>Cover Plates</u>			070-548904-09	H6
	2-419004	H4	27	318158-1	Wire Harness Assembly
	2-419015	H3	28	<u>Diffuser Panels</u>	
	2-419016	H6		1-419027	H3
8	1-318146	Prop Rod		2-419027	H4
9	<u>Ballast Assemblies</u>			3-419027	H6
	318157-1	H3	29	1-229205	Clip
	318157-2	H4	30	10-54722	#10 Pan Head Self Tapping Screw
	318157-3	H6	31	1-229281	Captive Panel Screw
10	<u>Top Panels</u>		32	1-131937	Retainer
	1-419071	H3			
	2-419071	H4			
	3-419071	H6			

# REEL CHANNEL ASSEMBLY

MODEL '324AR-H & 426AR-H

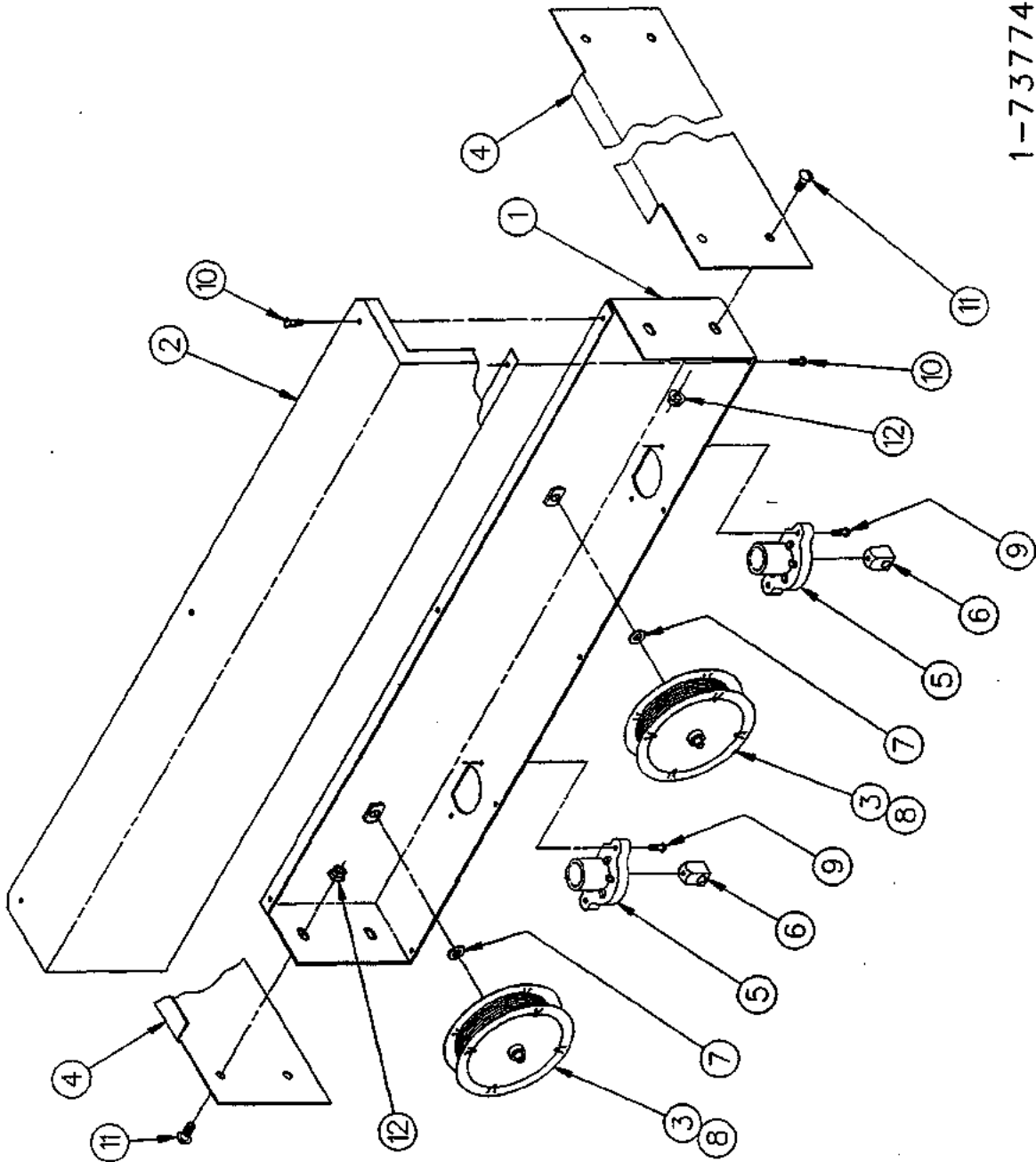

1-73774

## REEL CHANNEL ASSEMBLY

### Model 324AR-H & 426AR-H

ITEM NO.	PART NO.	DESCRIPTION
1		<u>Channel Reel Weld Assemblies</u>
	420105-3	30"
	420105-4	45"
2		<u>Reel Channel Cover</u>
	2-420103	30"
	2-420104	45"
3	24-410796	Reel Assembly (includes item #7 & #8)
4	2-420102	Reel Channel Support
5	1-223979	Eyelet
6	4-228630	Hose Clamp
7	08-50621	5/16 Flatwasher
8	4-126976	Cable (98" Large)
9	28-54568	#10-32 X 5/8 Large Phillips Round Head Self Tapping Screw
10	09-54668	#10-32 X 5/16 Large Pan Head Self Tapping Screw
11	464-50008	5/16-18 X 5/8 Large Round Head Machine Screw
12	02-54752	5/16-18 Whiz-Lock Nut

1-73774

# SIGHT GLASS ASSEMBLY FOR TCS

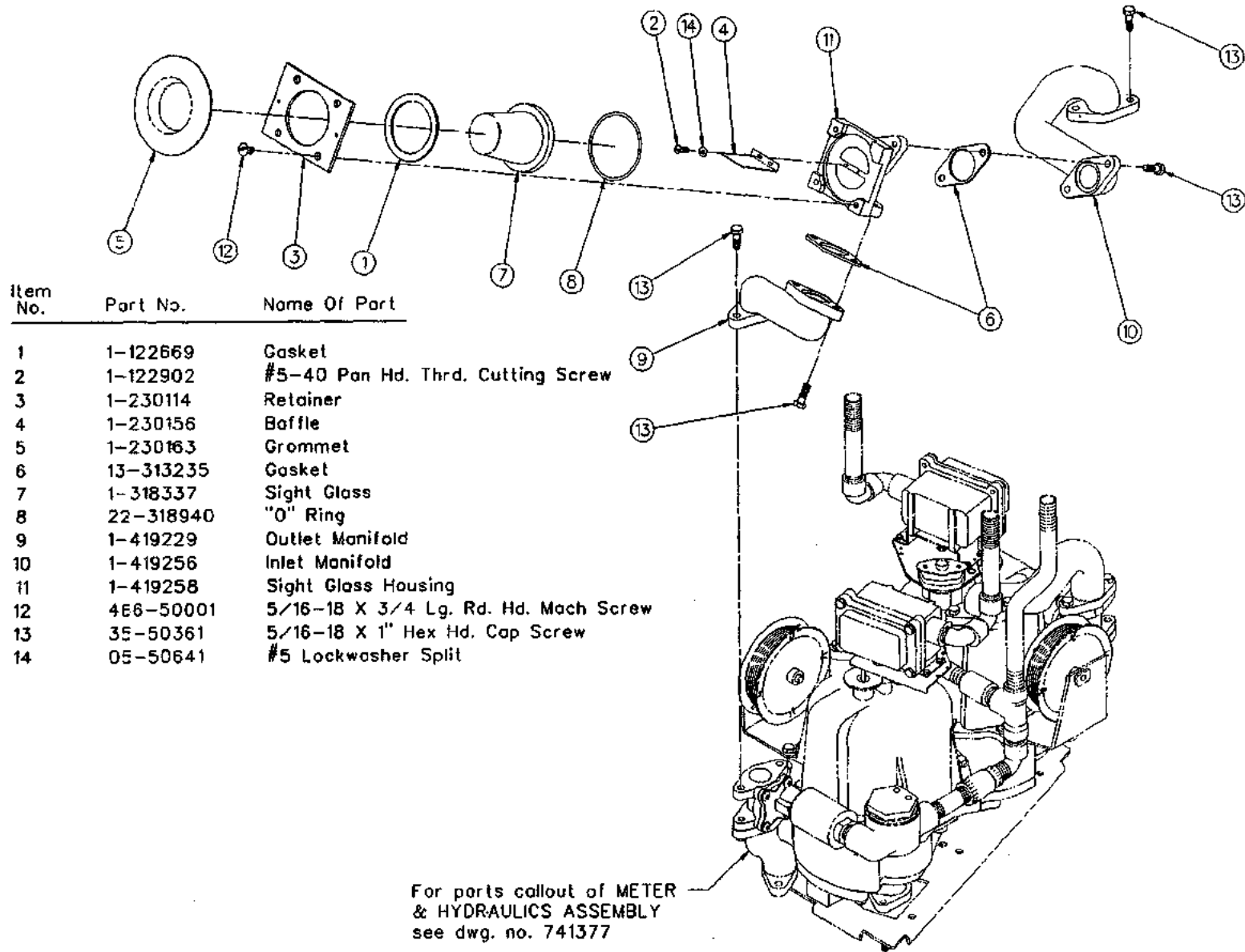

Item No.	Part No.	Name Of Part
1	1-122669	Gasket
2	1-122902	#5-40 Pan Hd. Thrd. Cutting Screw
3	1-230114	Retainer
4	1-230156	Baffle
5	1-230163	Grommet
6	13-313235	Gasket
7	1-318337	Sight Glass
8	22-318940	"O" Ring
9	1-419229	Outlet Manifold
10	1-419256	Inlet Manifold
11	1-419258	Sight Glass Housing
12	4E6-50001	5/16-18 X 3/4 Lg. Rd. Hd. Mach Screw
13	35-50361	5/16-18 X 1" Hex Hd. Cap Screw
14	05-50641	#5 Lockwasher Split



*Notes*

**LIGHTED VALANCE ASSEMBLY**  
**MODEL TCS HIGH HOSE**

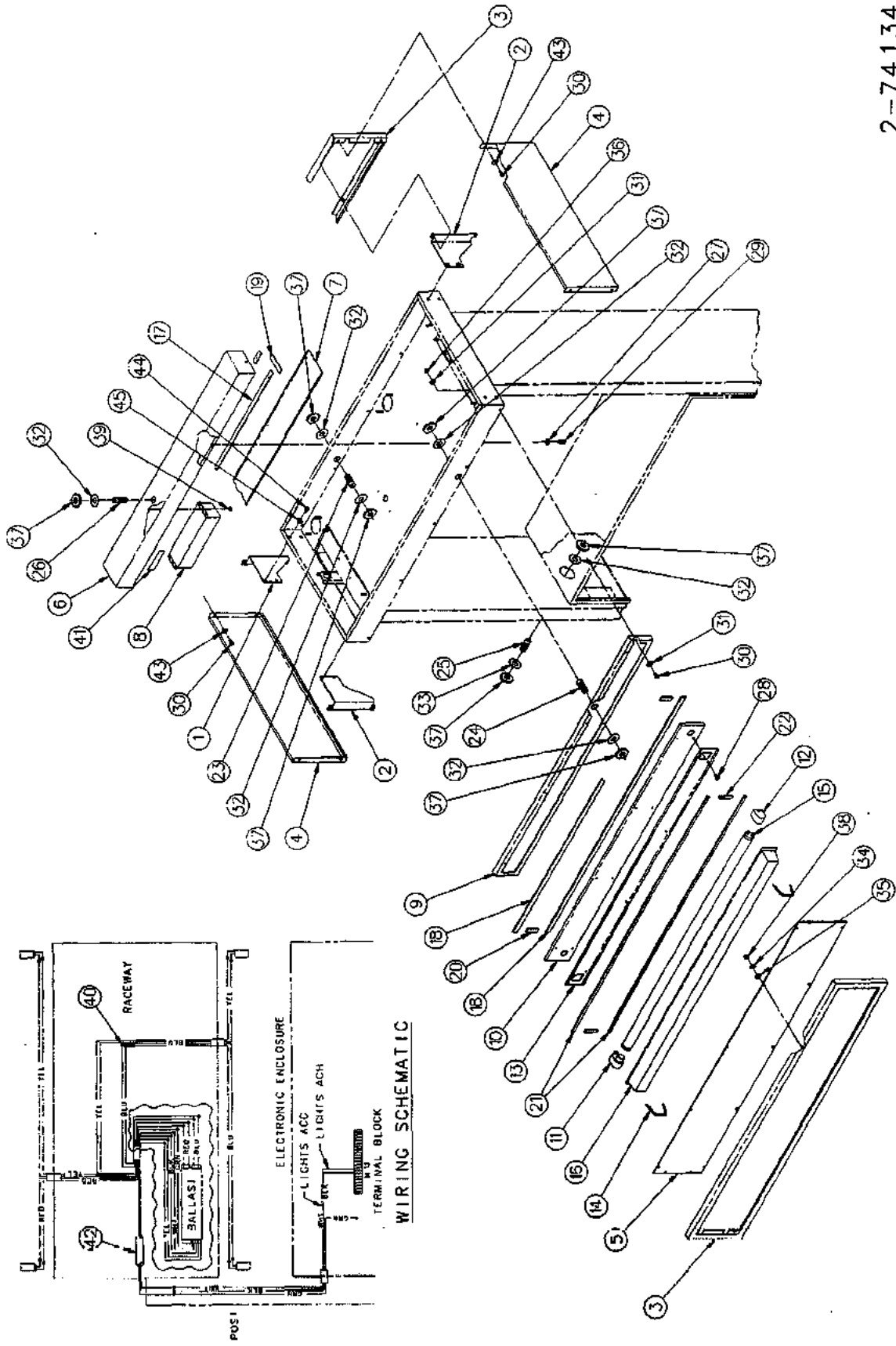

2-741341

## LIGHTED VALANCE ASSEMBLY

ITEM NO.	PART NO.	DESCRIPTION	ITEM NO.	PART NO.	DESCRIPTION	ITEM NO.	PART NO.	DESCRIPTION
1	318348-1	Right Support Weld Assembly	4	1-419815	End Panel (Painted)	12	2-226859	Lampholder
2	318348-2	Left Support Weld Assembly		2-419815	End Panel (Stainless)	13	<u>Tube Cover</u>	
3	1-419743	Side Panel (Painted)(30")	5	<u>Lexan Panel</u>			1-420111	HL 30"
	2-419743	Side Panel (Stainless)(30")		1-420114	HL 30"		1-419983	HL 45"
	420113-1	Side Panel Weld Assy. (Painted) (HL 30" only)		1-419996	HL 45"		1-420130	HL 60"
	420113-2	Side Panel Weld Assy. (Stainless) (HL 30" only)		1-420133	HL 60"	14	1-227691	Spring
	1-419239	Side Panel (Painted)(45")	6	<u>Ballast Box Weld Assembly</u>		15	<u>Fluorescent Lamp</u>	
	2-419239	Side Panel (Stainless)(45")		420116-1	HL 30"		3-226895	HL 60"
	419992-1	Side Panel Weld Assy. (Painted) (HL 45" only)		419998-1	HL 45"		4-226895	HL 30"
	419992-2	Side Panel Weld Assy. (Stainless) (HL 45" only)		420135-1	HL 60"		5-226895	HL 45"
	1-419756	Side Panel (Painted)(60")	7	<u>Ballast Box Cover</u>		16	<u>Lamp Cover</u>	
	2-419756	Side Panel (Stainless)(60")		1-420117	HL 30"		1-316833	HL 60"
	420132-1	Side Panel Weld Assy. (Painted) (HL 60" only)		1-420001	HL 45"		3-316833	HL 45"
	420132-2	Side Panel Weld Assy. (Stainless) (HL 60" only)		1-420136	HL 60"		4-316833	HL 30"
			8	1-316575	Ballast	17	<u>Cushion</u>	
			9	<u>Light Socket Raceway</u>			1-420007	HL 30"
				1-420109	HL 30"		2-420007	HL 45"
				1-419985	HL 45"		3-420007	HL 60"
				1-420128	HL 60"	18	<u>Cushion</u>	
			10	<u>Light Socket Cover</u>			11-317638	HL 45"
				1-420110	HL 30"		12-317638	HL 60"
				1-419989	HL 45"		13-317638	HL 30"
				1-420129	HL 60"	19	14-317638	Cushion
			11	1-226859	Lampholder	20	15-317638	Cushion

# LIGHTED VALANCE ASSEMBLY

ITEM NO.	PART NO.	DESCRIPTION	ITEM NO.	PART NO.	DESCRIPTION	ITEM NO.	PART NO.	DESCRIPTION
21	<u>Cushion</u>		34	05-50761	#10 Shakeproof Lockwasher			
	16-317638	HL 45"						
	17-317638	HL 30"	35	05-50621	#10 Plain Washer			
	18-317638	HL 60"						
22	19-317638	Cushion	36	02-50301	5/16-18 Hex Nut			
			37	1-130590	Hex Nut			
23	<u>Barrier Assembly</u>		38	05-50211	#10-24 Hex Nut			
	230399-1	(HL 30" & HL 60")	39	03-54752	#10-24 M-F Flange Whiz-Lock Nut			
	230399-2	(HL 45")	40	1-129223	Wire Connector			
24	<u>Barrier Assembly</u>		41	1-130404	Warning Label			
	230399-1	(HL 45")	42	058-5526-01	Flexible Loom			
	230399-2	(HL 30" & HL 60")	43	03-50611	5/16 Plate Washer			
25	<u>Barrier Assembly</u>		44	66-50361	3/8-16 x 1-1/4 Length Hex Head Cap Screw			
	230400-1	All Except HL322A-R-B5-V	45	1-132417	Aluminum Washer			
	230400-2	HL322-R-B5-V						
26	230401-1	Barrier Assembly						
27	71-37106	"O" Ring						
28	1-131282	Seal Screw						2-741341
29	4-227858	#8-32 X 5/16 Length Phillips Pan Head Screw						
30	32-50361	5/16-18 X 5/8 Length Hex Head Cap Screw						
31	1-131585	Aluminum Washer						
32	1-130613	Conduit Washer						
33	1-230384	Conduit Washer						

11-14