

Section Eight

Electronics

	Page Number
Connection Box Assembly	
Suction Series	8-2
RC Series	8-3
Ballast and Lamp Assemblies	
Front lighted TCS Non-A	8-4, 8-5
Front lighted TCS Non-A (Steel Enclosure)	8-6, 8-7
Back lighted Ballast Assembly, TCS-A Three piece Dial	8-8, 8-9
Back lighted Ballast & Lamp Assembly, TCS-A One Piece Dial ...	8-10, 8-11
Relay Assembly	
TCS Non-A	8-13
Cage and Power Supply Assemblies	
Cage & Power Supply Assembly for TCS Non-A	8-14, 8-15
Power Supply TCS Non-A	8-16, 8-17
Valve Power Supply for Electronic Blender TCSA	8-18, 8-19
Electrical Component & Power Supply Assembly TCSA	8-20, 8-21
TCS Card Cage Assembly (System Boards)	8-22 — 8-25
Miscellaneous Electrical Components	
Terminal Strip Assembly	8-26
Manager's Keylock Assembly TCS Non-A	8-27
Barrier Conduit Assembly	8-28
3 - 5 Product Variable Blender	
322A-R-B5 Card Cage Assembly	8-30, 8-31
Power Supply & Card Cage (including system boards)	8-32, 8-33
Wiring Schematics	
Model 300, 400, 600 Non-A	8-34, 8-35
Model 300A, 400A, 600A	8-36, 8-37
Model 300A-B3/B5	8-38, 8-39
Model 411A, 422A	8-40, 8-41
MaxVac, All Models Except 30" Variable Blenders	8-42, 8-43
MaxVac, TCS "A" 30" Variable Blender	8-44, 8-45
MaxVac Assemblies	
Motor Control Assembly, Model 400A & 600A	8-46, 8-47
Power Supply & Motor Control Assembly, Model 300A	8-48, 8-49
Options Power Supply Assembly, Model 300A	8-50, 8-51
Options Power Supply Assembly, Model 400A & 600A	8-52, 8-53

T
C
S

D
I
S
P
E
N
S
E
R

ITEM NO.	PART NO.	DESCRIPTION
1	1-131270	Special Screw
2	1-131322	Cup Washer
3	1-218941	Expansion Union (Male-Female)
4	1-218992	Expansion Union (Female-Female)
5	<u>Wire Connector</u>	
	3-224492	16-22 Gauge (AC & DC)
	6-224492	14-16 Gauge (AC Only)
6	4-224494	#10 Ring Terminal
7	1-227938	Terminal Strip
8	1-228342	Spacer
9	<u>Label</u>	
	1-228397	AC
	2-228397	DC
10	1-228647	Conduit
11	1-228945	Jumper (AC Only)
12	1-317834	Insulator
13	416806-42	Lead Assembly
14	1-417378	Connection Box Cover
15	1-418048	Connection Box
16	1-418245	Conduit
17	<u>Wire Harness Assembly</u>	
	319993-1	AC (120/240 Volt)
	319993-2	DC (30" & 45")
	319993-3	DC (60" A)
	319993-4	DC (60")
	319993-5	DC (30" A)
	319993-6	DC (45" A)
	319993-7	AC (30" Brazil)
	319993-10	AC (380 Volt)
	319993-11	AC (380 Volt)(45" A Mobil)
18	92-50001	#6-32 x 3/8" Long Round Head Machine Screw
19	02-50361	1/4-20 x 5/8" Long Hex Head Cap Screw
20	04-50361	1/4-20 x 7/8" Long Hex Head Cap Screw
21	35-50361	5/16-18 x 1" Long Hex Head Cap Screw
22	13-50641	1/4" Lockwasher
23	04-51901	1/2" Pipe Plug
24	06-51901	1" Pipe Plug

Reference: 418238 Connection Box Assembly

CONNECTION BOX ASSEMBLY

TCS SUCTION SERIES

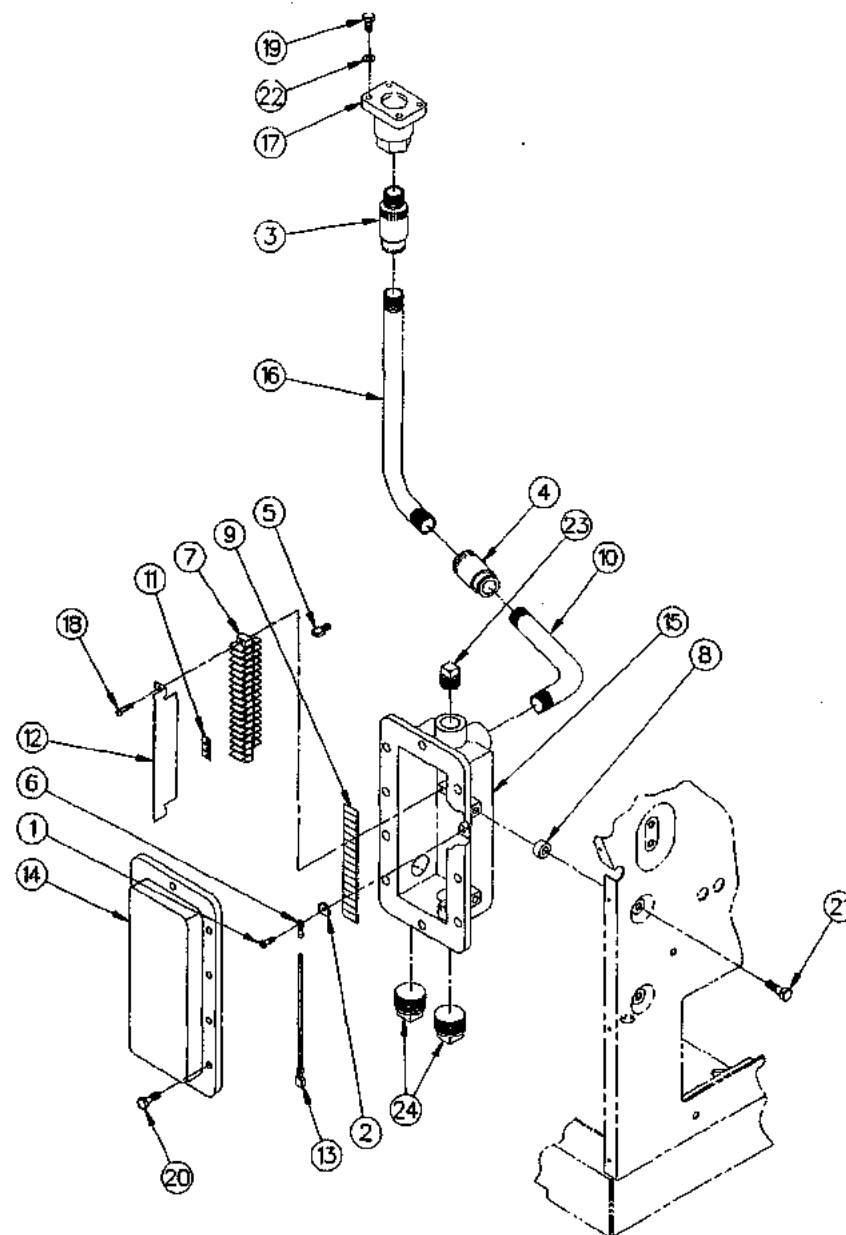

2-741386

2-741386

CONNECTION BOX ASSEMBLY

TCS REMOTE CONTROL SERIES

TCS/TCSA Dispenser Parts Manual
 Form 4576A Version 1.0
 Tokheim Corporation February 1996

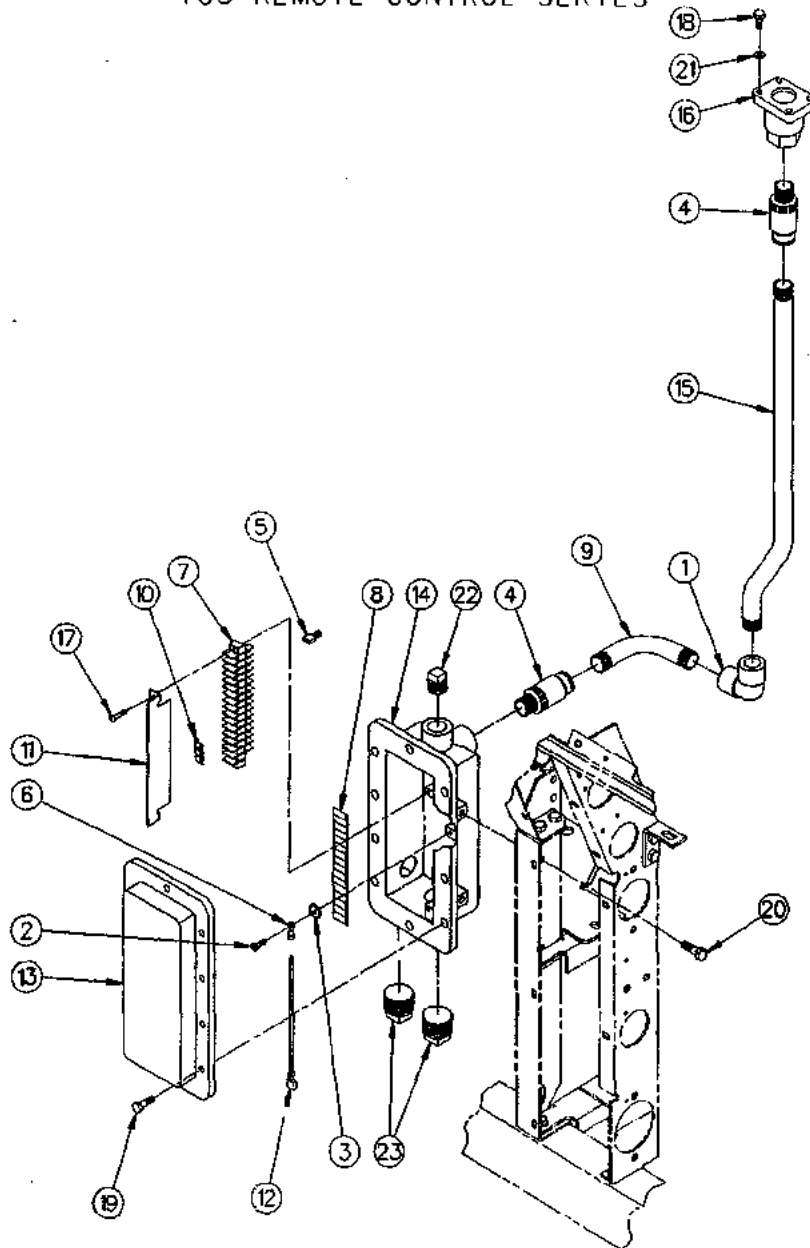

ITEM NO.	PART NO.	DESCRIPTION
1	1-118345	1/2" Conduit Elbow
2	1-131270	Special Screw
3	1-131322	Cup Washer
4	1-218941	Expansion Union (Male-Female)
5	Wire Connector	
	3-224492	16-22 Gauge (AC & DC)
	6-224492	14-16 Gauge (AC Only)
6	4-224494	#10 Ring Terminal
7	1-227938	Terminal Strip
8	Label	
	1-228397	AC
	2-228397	DC
9	1-228662	Conduit
10	1-228945	Jumper (AC Only)
11	1-317834	Insulator
12	416806-42	Lead Assembly
13	1-417378	Connection Box Cover
14	1-418048	Connection Box
15	1-418246	Conduit
16	Wire Harness Assembly	
	319993-1	AC (30", 45" & 60")
	319993-3	DC (30", 45" & 60")
	319993-8	AC (311A/322A-R-B3/B5)
	319993-9	DC (311A/322A-R-B3/B5)
17	92-50001	#6-32 x 3/8" Long Round Head Machine Screw
18	02-50361	1/4-20 x 5/8" Long Hex Head Cap Screw
19	04-50361	1/4-20 x 7/8" Long Hex Head Cap Screw
20	35-50361	5/16-18 x 1" Long Hex Head Cap Screw
21	13-50641	1/4" Lockwasher
22	04-51901	1/2" Pipe Plug
23	06-51901	1" Pipe Plug

Reference: 418238 Connection Box Assembly

3-741387

FRONT LIT BALLAST & LAMP ASSEMBLY

(TCS NON "A")

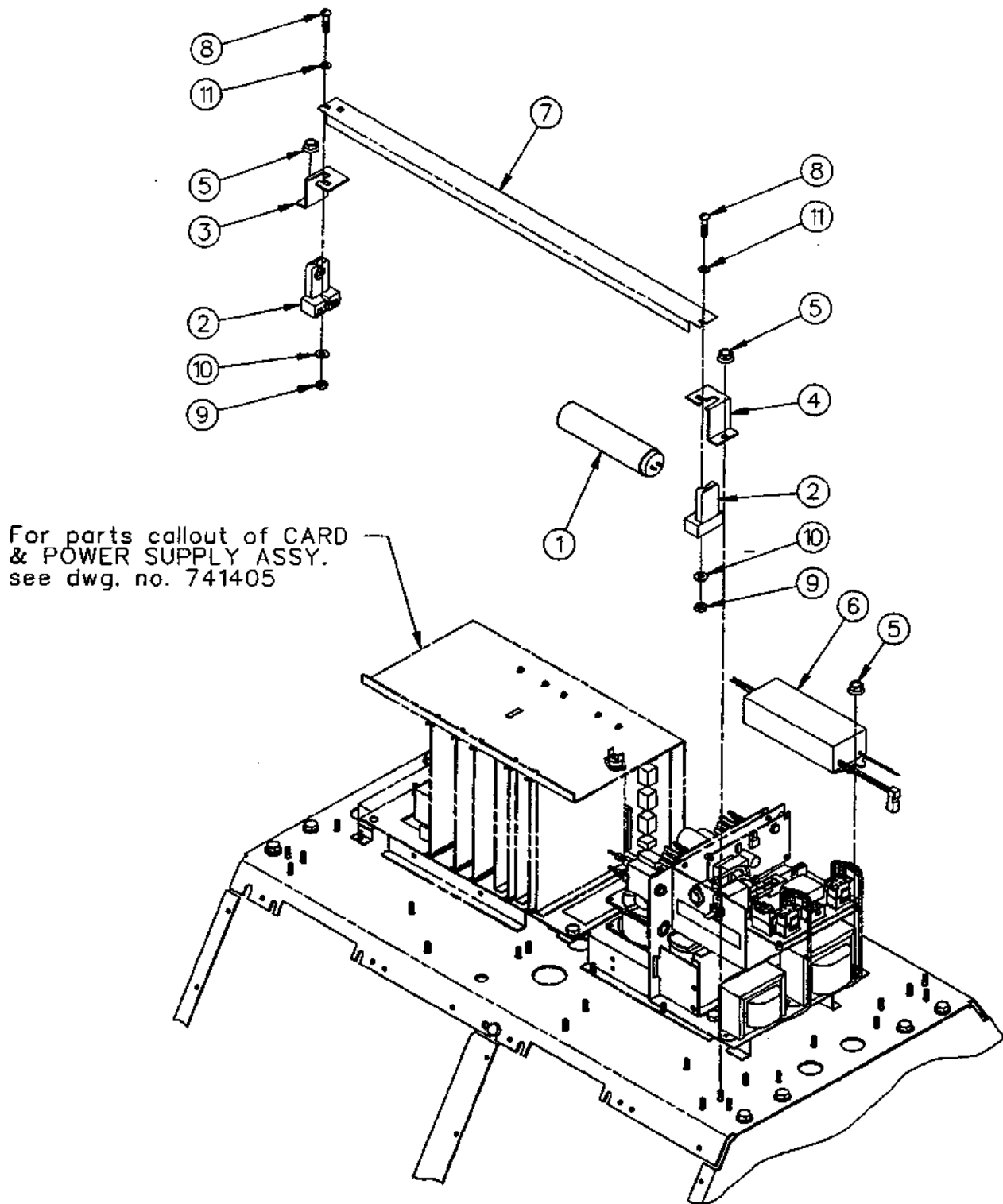

2-741415

FRONT LIT BALLAST & LAMP ASSY.
(TCS NON "A")

2-
741415

1 of 1

ITEM NO.	PART NO.	DESCRIPTION
1	<u>Fluorescent Lamp</u>	
	12-219435	30" & 60" (Case)
	13-219435	45" (Case)
2	1-221379	Lamp Holder
3	1-228666	Left Lamp Mounting Bracket
4	2-228666	Right Lamp Mounting Bracket
5	2-228671	#10-24 Capped Washer Locknut
6	<u>Ballast & Harness Assembly</u>	
	229677-1	220 Volt 50Hz (311 & 312)
	229677-2	220 Volt 50Hz (322, 324 & 614)
	229677-3	220 Volt 50Hz (426)
	229677-4	220 Volt 50Hz (413)
	229677-5	220 Volt 50Hz (628)
	317474-1	120 Volt (All 30" & 60")
	1-418534	120 Volt (All 426)
	2-418534	120 Volt (All 413)
7	<u>Starter Strip</u>	
	1-418298	All 30" & 60"
	2-418298	All 45"
8	182-50001	#8-32 x 1" Long Round Head Machine Screw
9	04-50211	#8-32 Hex Nut
10	04-50621	#8 Plain Washer
11	04-50761	#8 Shakeproof Lockwasher

2-741415

FRONT LIT BALLAST & LAMP ASSEMBLY

(TCS NON "A")

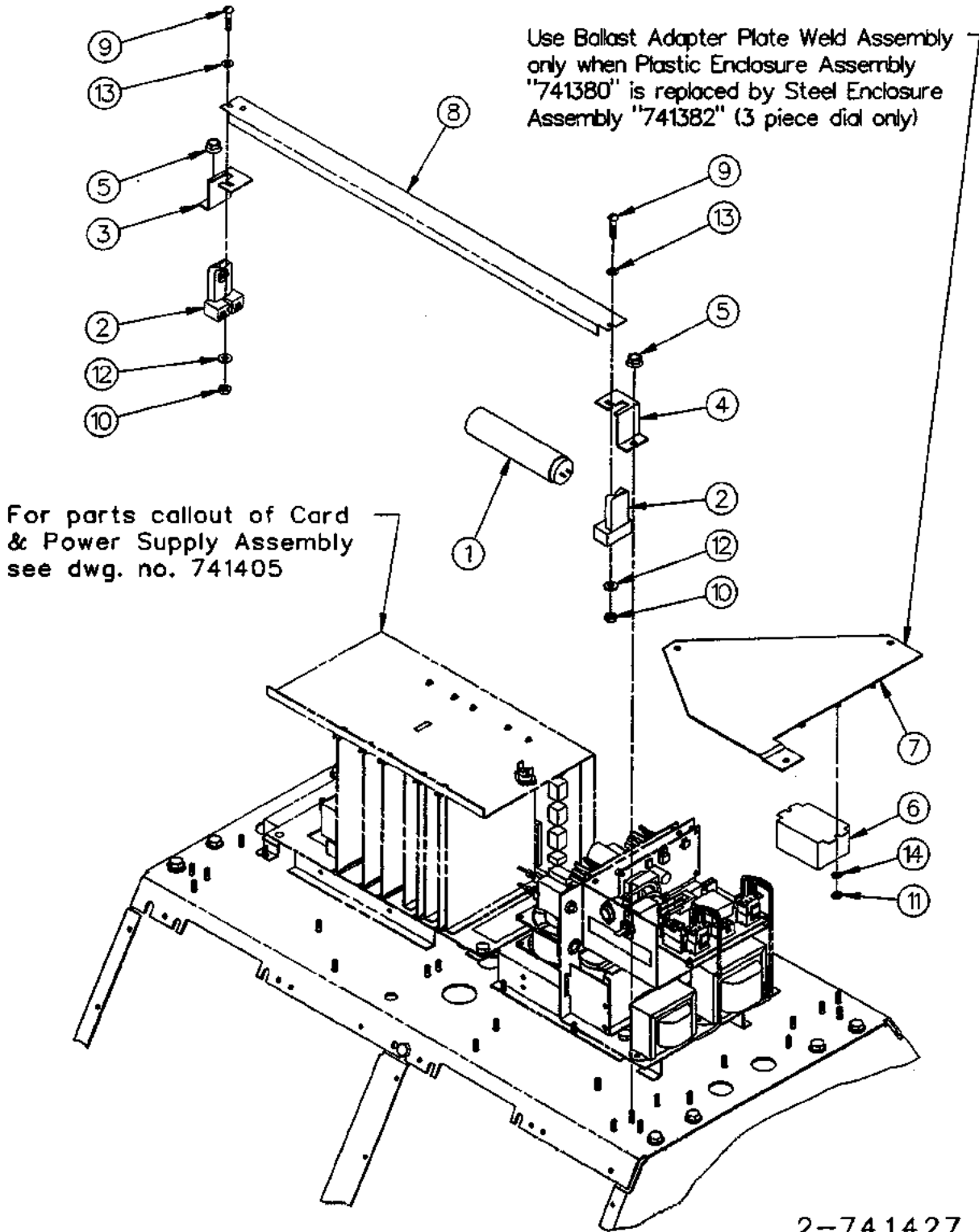

FRONT LIT BALLAST & LAMP ASSY.

(TCS NON "A")

2-

741427

1 of 1

ITEM NO.	PART NO.	DESCRIPTION
1	<u>Fluorescent Lamp</u>	
	12-219435	30" & 60" (Case)
	13-219435	45" (Case)
2	1-221379	Lamp Holder
3	1-228666	Left Lamp Mounting Bracket
4	2-228666	Right Lamp Mounting Bracket
5	2-228671	#10-24 Capped Washer Locknut
6	<u>Ballast & Harness Assembly</u>	
	229677-1	220 Volt 50Hz (311 & 312)
	229677-2	220 Volt 50Hz (322, 324 & 614)
	229677-3	220 Volt 50Hz (426)
	229677-4	220 Volt 50Hz (413)
	229677-5	220 Volt 50Hz (628)
	317474-1	120 Volt (All 30" & 60")
	1-418534	120 Volt (All 426)
	2-418534	120 Volt (All 413)
7	<u>Ballast Adapter Plate Weld Assembly</u>	
	319070-1	45" & 60"
	319078-1	30"
8	<u>Starter Strip</u>	
	1-418298	All 30" & 60"
	2-418298	All 45"
9	182-50001	#8-32 x 1" Long Round Head Machine Screw
10	04-50211	#8-32 Hex Nut
11	05-50211	#10-24 Hex Nut
12	04-50621	#8 Plain Washer
13	04-50761	#8 Shakeproof Lockwasher
14	23-50761	#10 Shakeproof Lockwasher

2-741427

BACK LIT BALLAST ASSEMBLY

TCS "A" (THREE PIECE DIAL ONLY)

Use Ballast Adapter Plate Weld Assembly only when Plastic Enclosure Assembly "741380" is replaced by Steel Enclosure Assembly "741382" (3 piece dial only)

For parts callout of Electrical Component & Power Supply Assembly see dwg. no. 741310

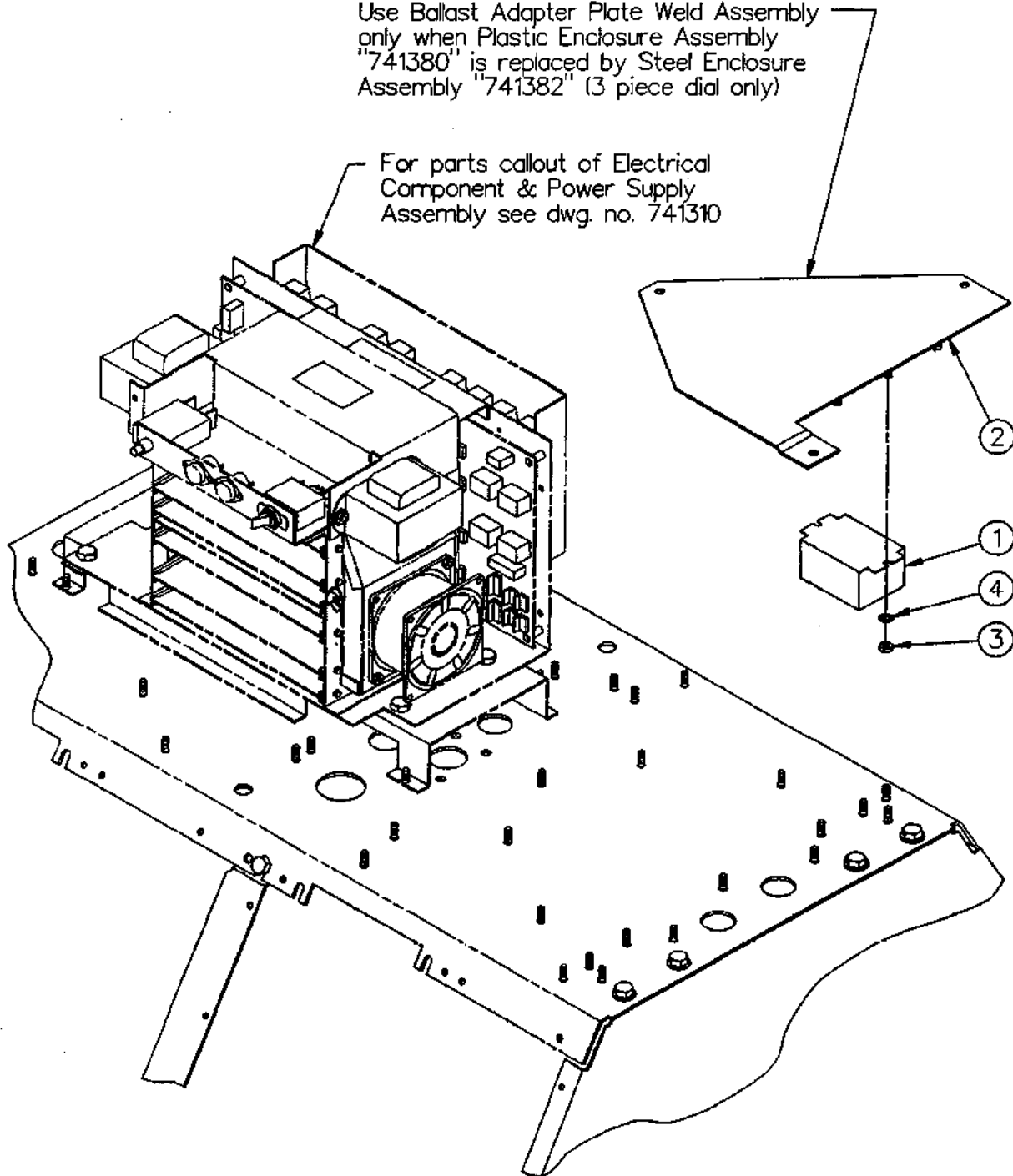

2-741416

BACK LIT BALLAST ASSEMBLY
TCS "A" (THREE PIECE DIAL ONLY)

2-
741416

1 of 1

ITEM NO.	PART NO.	DESCRIPTION
1	<u>Ballast</u>	
	1-315556	110 Volt
	3-315556	240 Volt 50Hz
	4-315556	240 Volt 60Hz
2	<u>Ballast Adapter Plate Weld Assembly</u>	
	319070-1	45" & 60"
	319078-1	30"
3	05-50211	#10 Hex Nut
4	23-50761	#10 Shakeproof Lockwasher

2-741416

BACK LIT BALLAST & LAMP ASSEMBLY

TCS "A" (ONE PIECE DIAL)

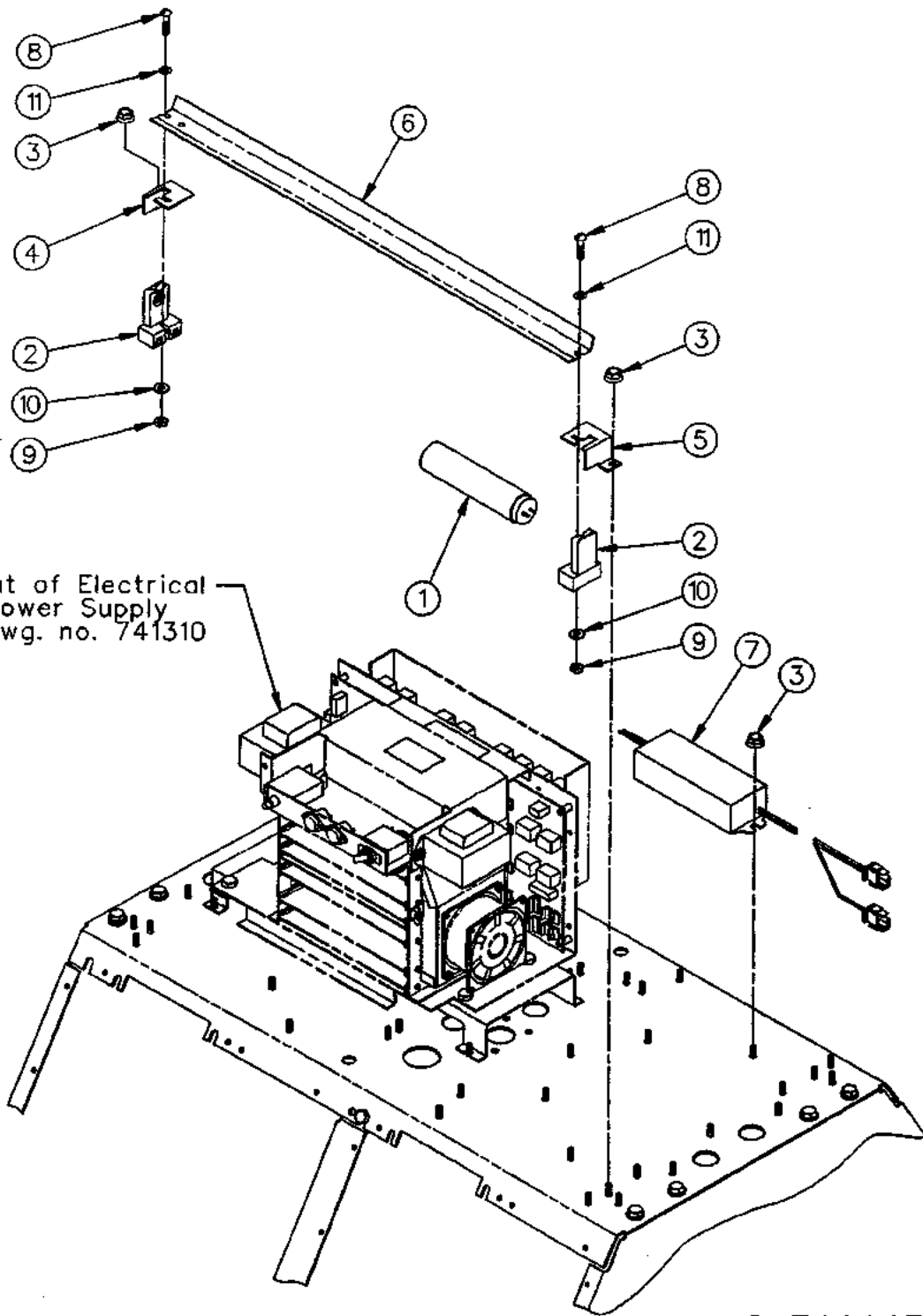

BACK LIT BALLAST & LAMP ASSEMBLY 741417

TCS "A" (ONE PIECE DIAL)

1 of 1

ITEM NO.	PART NO.	DESCRIPTION
1	<u>Fluorescent Lamp</u>	
	12-219435	30" & 60" (Case)
	13-219435	45" (Case)
2	1-221379	Lamp Holder
3	2-228671	#10-24 Capped Washer Locknut
4	1-318962	Right Lamp Mounting Bracket
5	2-318962	Left Lamp Mounting Bracket
6	<u>Reflector</u>	
	2-420464	All 45"
	2-420531	All 30" & 60"
7	<u>Ballast & Harness Assembly</u>	
	420488-1	120 Volt (413A)
	420488-2	120 Volt (426A)
	420488-3	120 Volt (312A, 324A, 614A & 628A)
	420488-5	230 Volt 50Hz (413A)
	420488-6	230 Volt 50Hz (426A)
	420488-7	220 Volt 50Hz (312A, 324A, 614A & 628A)
	420488-8	230 Volt 60Hz (413A)
	420488-9	230 Volt 60Hz (426A)
	420488-10	220 Volt 60Hz (312A, 324A, 614A & 628A)
8	182-50001	#8-32 x 1" Long Round Head Machine Screw
9	04-50211	#8-32 Hex Nut
10	04-50621	#8 Plain Washer
11	04-50761	#8 Shakeproof Lockwasher

2-741417

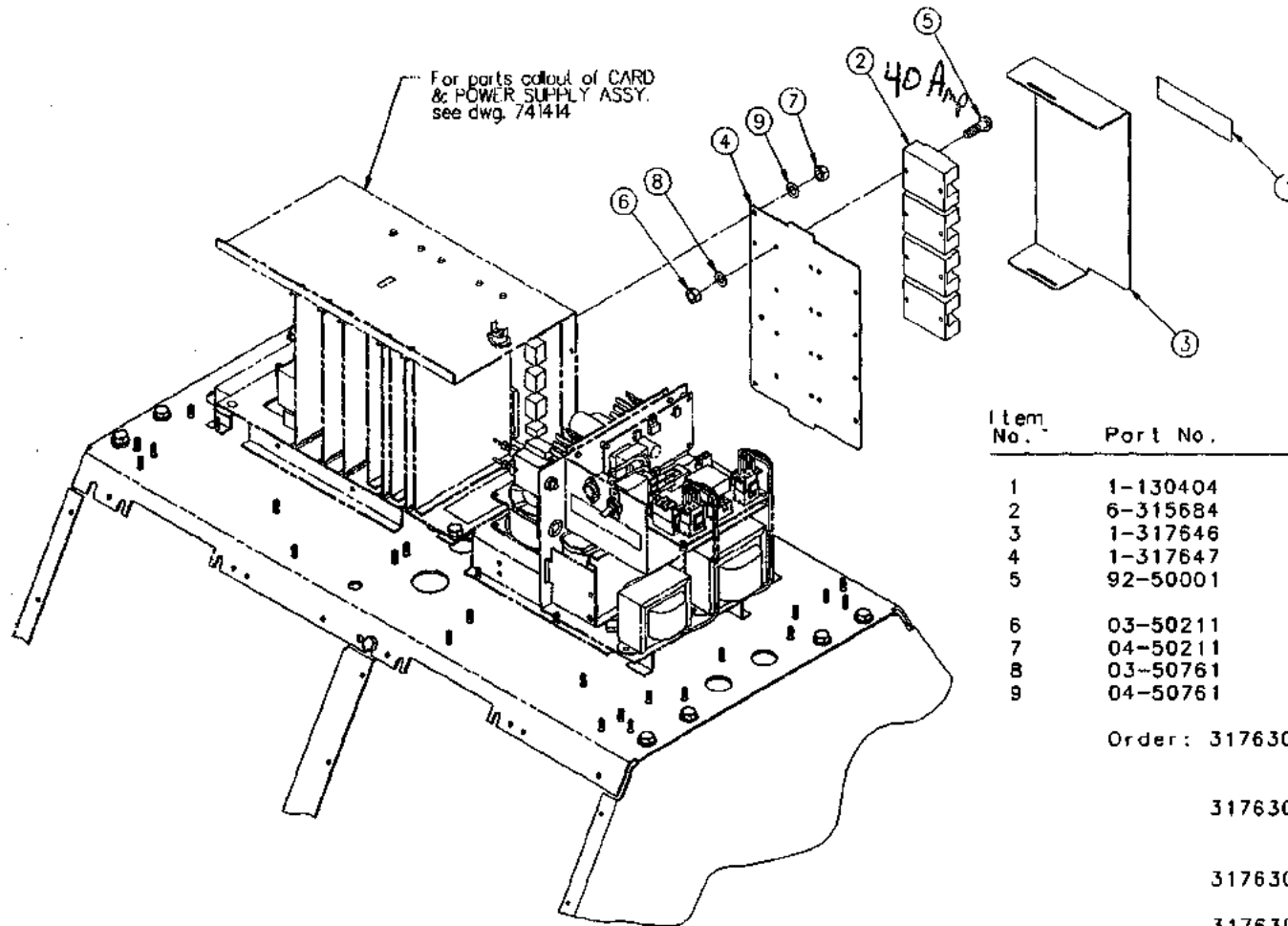
RELAY ASSEMBLY (FOR TCS NON "A" SERIES)

Item No.	Part No.	Name Of Part
1	1-130404	Warning Label
2	6-315684	Power Relay 40 Amp
3	1-317646	Cover
4	1-317647	Relay Bracket
5	92-50001	#6-32 X 3/8 Rd. Hd. Mach Screw
6	03-50211	#6-32 Hex Nut
7	04-50211	#8-32 Hex Nut
8	03-50761	#6 Shakeproof Lockwasher
9	04-50761	#8 Shakeproof Lockwasher

Order: 317630-1 for complete Relay And Bracket Assy. (311, 312 & 322)
 317630-2 for complete Relay And Bracket Assy. (324, 413 & 614)
 317630-3 for complete Relay And Bracket Assy. (426)
 317630-4 for complete Relay And Bracket Assy. (628)

1-741414



Notes

CAGE & POWER SUPPLY ASSEMBLY

(FOR TCS NON "A" SERIES)

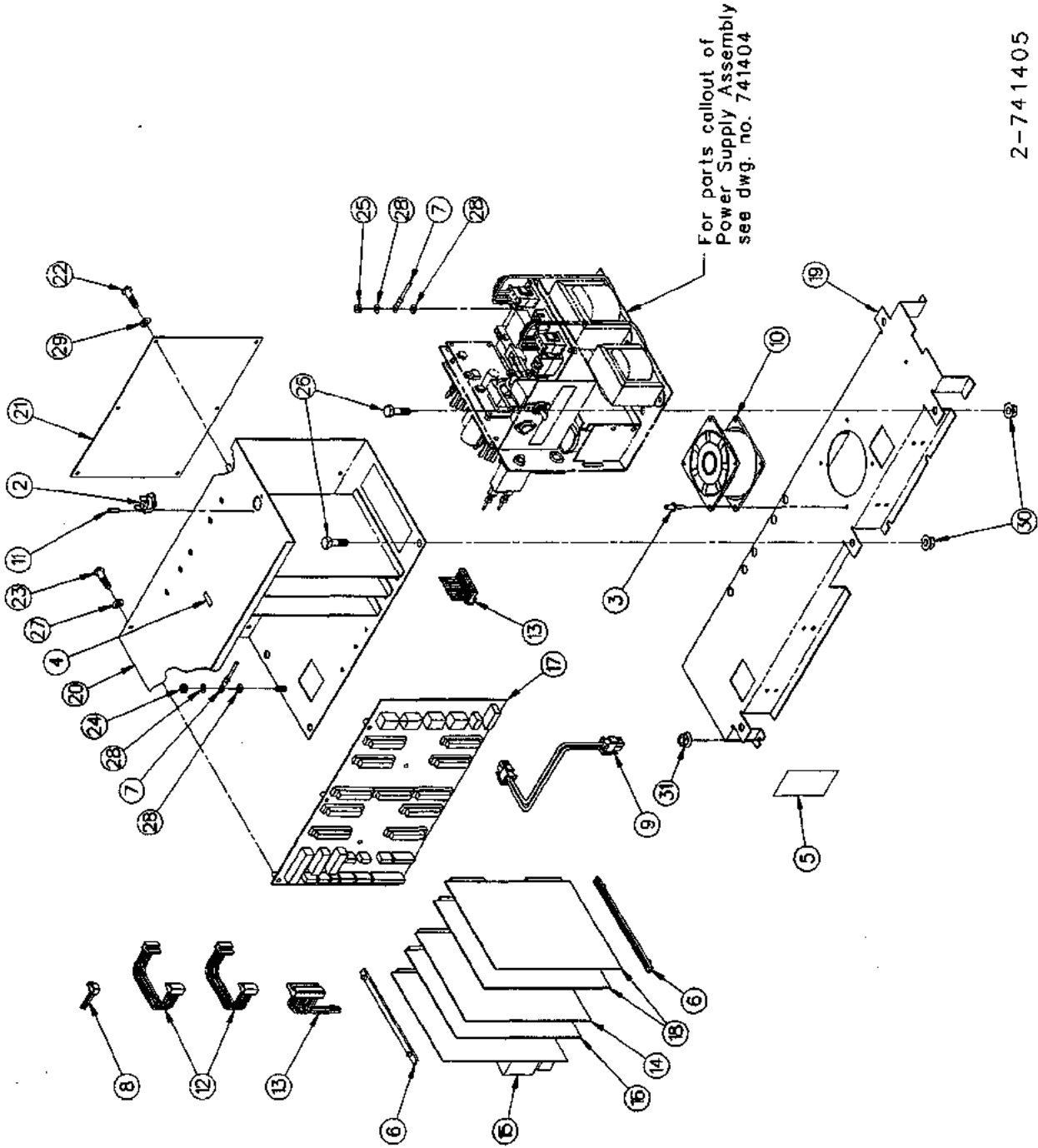

2-741405

CAGE & POWER SUPPLY ASSEMBLY

(FOR TCS NON "A" SERIES)

ITEM NO.	PART NO.	DESCRIPTION	ITEM NO.	PART NO.	DESCRIPTION
1	1-128725	Cable Tie (Not Shown)	18		<u>Relay Board Assembly</u>
2	6-130217	Thermostat		420322-5	All Models Except Listed Below
3	2-131006	Pop Rivet		420322-6	311, 322, 413 & 426 (Side "A")
4	23-220949	"W" Wire Marker	19	1-418121	Base Plate
5	1-226445	Warning Label	20	418145-1	Card Cage Weld Assembly
6	1-227818	Card Guide	21		<u>Switch Light Control Board Assembly</u>
7	227885-1	Ground Harness Assembly		418560-1	45" & 60" Only
8	228398-1	Console Wire Harness Assembly		418560-2	30" Only
9	228614-1	Power Distribution Wire Harness Assembly	22	88-50001	#6-32 x 1/4" Long Round Head Machine Screw
10		<u>Fan Assembly</u>	23	90-50001	#6-32 x 5/16" Long Round Head Machine Screw
	228665-1	120 Volt	24	05-50211	#10-24 Hex Nut
	228665-3	220 Volt	25	13-50211	#10-32 Hex Nut
11	1-229652	Plastic Rivet	26	31-50361	5/16-18 x 1/2" Long Hex Head Cap Screw
12	317476-6	Junction Wire Harness Assembly	27	03-50761	#6 Shakeproof Lockwasher
13	317481-1	Power Control Wire Harness Assembly	28	05-50761	#10 Shakeproof Lockwasher
14	417333-4	Multiplex Board Assembly	29	21-50761	#6 Shakeproof Lockwasher
15	417812-2	Interface Board Assembly	30	02-54752	5/16-18 M-F Flange Whiz Lock Nut
16	417815-3	Computer Board Assembly	31	2-228671	#10-24 Capped Washer Locknut
17		<u>Mother Board</u>			
	417829-1	All Models Except Listed Below			
	417829-2	Mechanical Blender only			

TCS/TCSA Dispenser Parts Manual
Form 4576A Version 1.0
Tokheim Corporation February 1996

POWER SUPPLY ASSEMBLY FOR TCS NON "A"

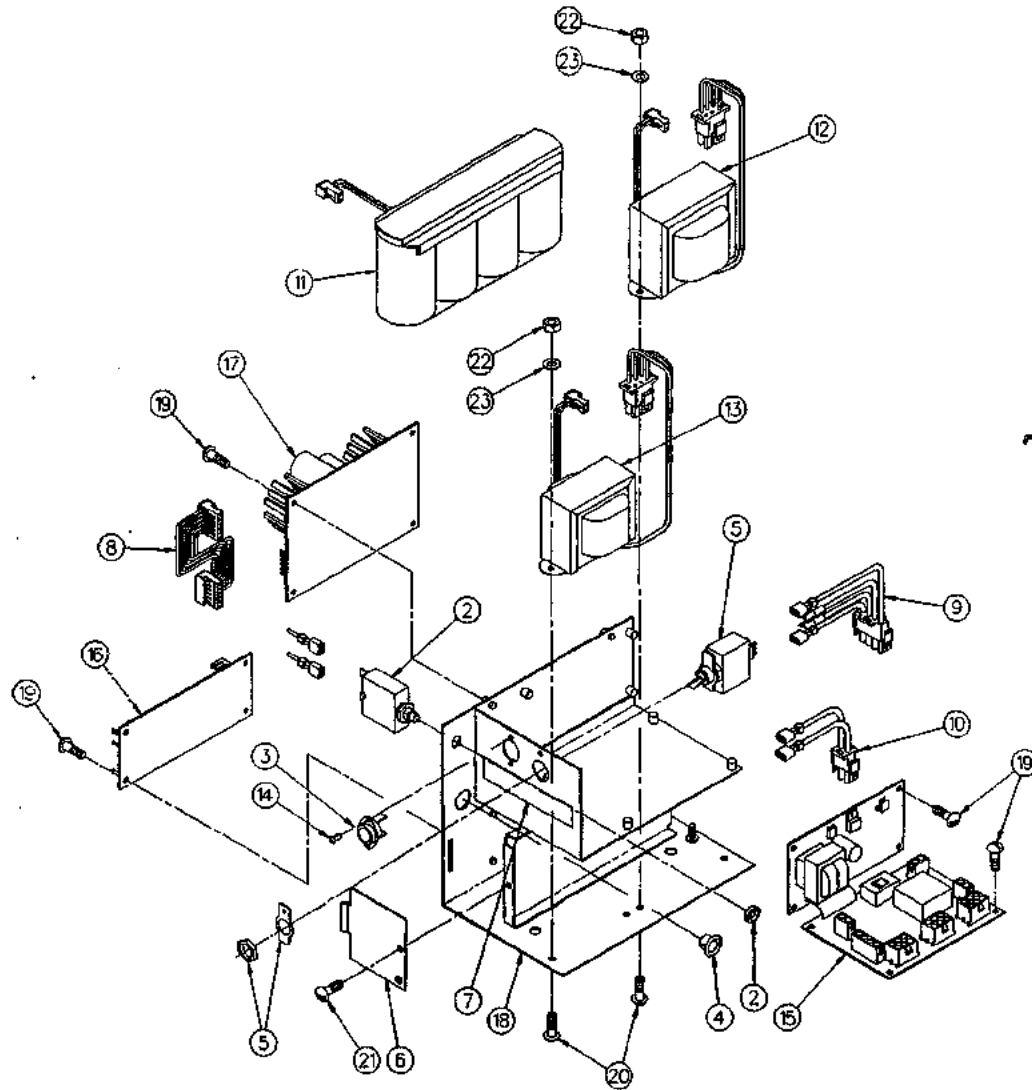

Item No.	Part No.	Name Of Part
1	1-128725	Cable Tie (not shown)
2	3-129138	1.5A Circuit Breaker
3	3-130217	Thermostat
4	1-225460	Bushing
5	1-227360	3.5A Circuit Breaker
6	227791-1	Door Assembly
7	1-227816	Label
8	227875-1	Power Supply/Control Wire Harness Assembly
9	227876-1	Circuit Breaker Wire Harness Assembly
10	227877-1	Thermostat Wire Harness Assy.
11	227884-2	Battery Pack Assembly
12	227887-1	Transformer Assembly
13	227887-2	Transformer Assembly
14	1-229652	Plastic Rivet
15	316931-1	Console Isolation Board Assy.
16	316934-1	Power Control Board Assy.
17	417346-1	Power Supply Board Assy.
18	417399-1	Mounting Plate Weld Assy.
19	88-50001	#6-32 X 1/4 Lg. Rd. Hd. Mach Screw
20	170-50001	#8-32 X 3/8 Lg. Rd. Hd. Mach Screw
21	88-50031	#6-32 X 1/4 Lg. Truss Hd. Mach Screw
22	04-50211	#8-32 Hex Nut
23	04-50761	#8 Shakeproof Lockwasher

Order 417514-1 for complete Power Supply
Assembly

1-741404



**VALVE POWER SUPPLY
FOR ELECTRONIC BLENDER (TCS "A")**

ITEM NO.	PART NO.	DESCRIPTION
1	1-130404	Warning Label
2	1-225460	Bushing
3	1-227360	Circuit Breaker
4	2-228671	#10-24 Capped Washer Locknut
5	3-230395	Faston Tab
6	4-230395	Faston Tab
7	5-230395	Faston Tab
8	<u>Fan</u>	
	1-230737	115 Volt
	2-230737	230 Volt
9	230743-1	Circuit Board Wire Harness Assembly
10	1-230758	Terminal Block
11	1-230983	Cover
12	318823-1	Right Adapter Weld Assembly
13	<u>Circuit Breaker Wiring Harness Assembly</u>	
	318883-1	426A-REB
	318883-2	628A-REB
	318883-3	322A-RB5
14	1-318887	Terminal Bracket
15	318915-1	Transformer Assembly
16	420165-10	Fan Lead Assembly
17	420350-1	Heat Sink/Board Mounting Assembly
18	178-50001	#8-32 x 3/4" Long Round Head Machine Screw
19	252-50001	#10-24 x 3/8" Long Round Head Machine Screw
20	03-50211	#6-32 Hex Nut
21	04-50211	#8-32 Hex Nut
22	04-50621	#8 Plain Washer
23	03-50761	#6 Shakeproof Lockwasher
24	04-50761	#8 Shakeproof Lockwasher
25	109-50001	#6-32 x 1-3/8" Long Round Head Machine Screw
 <u>For complete Valve Power Supply Assembly order:</u>		
	420349-1	426A-REB
	420349-2	628A-REB
	420349-3	322A-RB5
<hr/> 2-741442 <hr/>		

ELECTRICAL COMPONENT & POWER SUPPLY ASSY
MODEL 300A, 400A & 600A SERIES

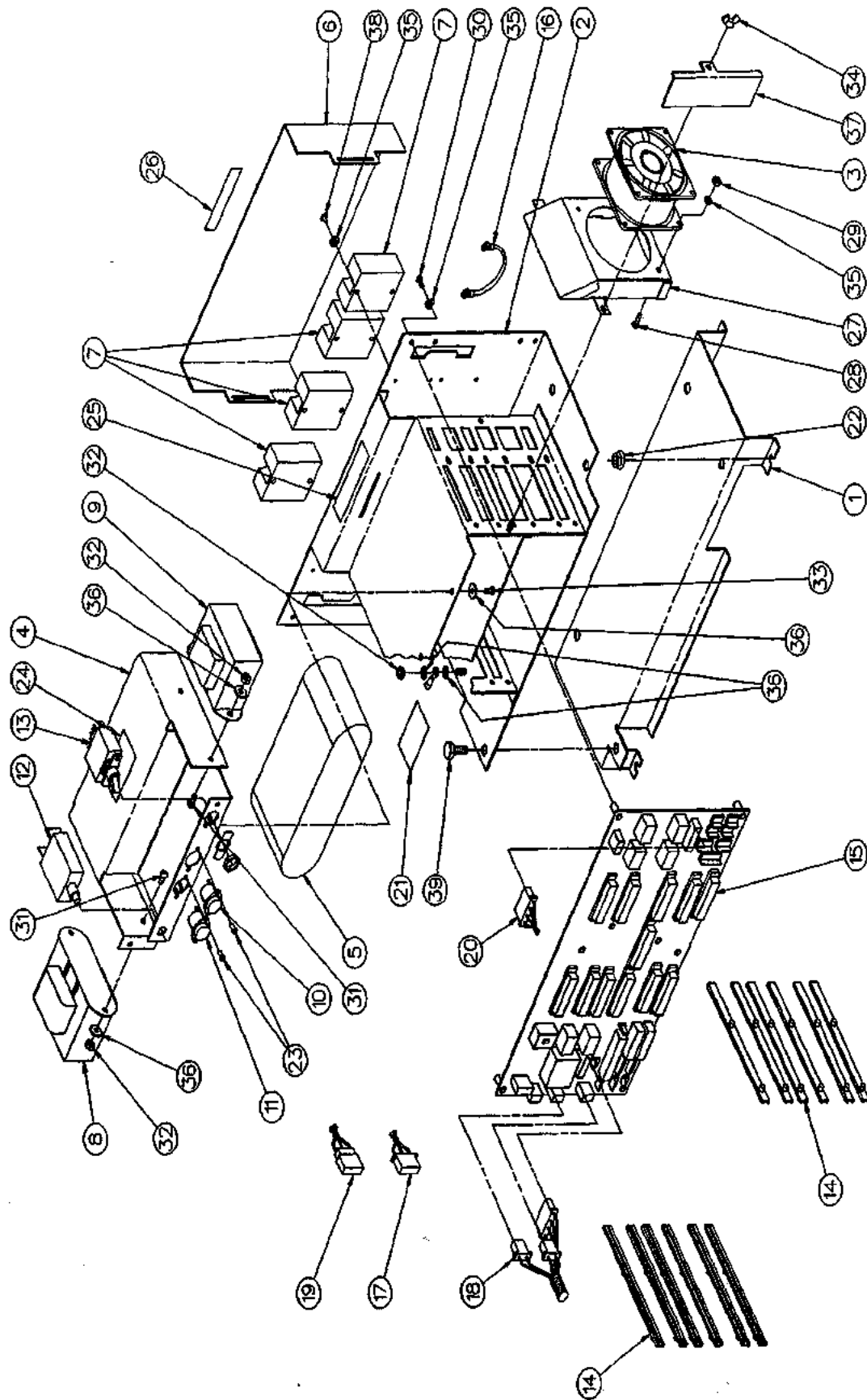

3-741310

3-741310

1 of 1

ELECTRICAL COMPONENT & POWER SUPPLY ASSEMBLY MODEL 300A, 400A, & 600A SERIES

ITEM NO.	PART NO.	DESCRIPTION	ITEM NO.	PART NO.	DESCRIPTION	ITEM NO.	PART NO.	DESCRIPTION
1	419629-1	Base Plate Weld Assembly	16	230101-1	Wire Harness Assembly (312A, 324A, 413A, 426A, 426A-REB, 614A & 628A)	26	1-227816	Label
2	419223-1	Card Cage Weld Assembly				27	318269-1	Fan Shroud Weld Assembly
3	<u>Fan Assembly</u>					28	92-50021	#6-32 x 3/8" Long Phillips Round Head Machine Screw
	228665-2	110 Volt	17	<u>Wiring Harness Assembly</u>		29	03-50211	#6-32 Mach Nut
	228665-3	220 Volt		230102-1	311A & 322A	30	88-50001	#6-32 x 1/4" Long Round Head Machine Screw
4	419628-1	Battery Bracket Weld Assmby		230102-2	312A, 324A & 426A-REB	31	170-50001	#8-32 x 3/8" Long Round Head Machine Screw
5	318349-3	Battery Assembly		230102-3	413A & 426A	32	04-50211	#8-32 Hex Nut
6	1-318217	Relay Cover		230102-4	614A & 628A	33	166-52851	#8-32 x 1/4" Long Hex Head Machine Screw
7	6-315684	Power Relay	18	230108-1	Loom & Harness Assembly	34	03-50381	#8-32 Wing Nut
8	230104-1	Transformer Assembly (HV)				35	03-50761	#6 Lockwasher
9	230105-1	Transformer Assembly (LV)	19	<u>Wiring Harness Assembly</u>		36	04-50761	#8 Lockwasher
10	6-130217	Thermostat		230110-1	311A & 322A	37	1-319232	Card Retainer
11	3-130217	Thermostat		230110-2	312A, 324A & 426A-REB	38	19-51441	#6 x 3/8" Long Round Head Self Tapping Screw
12	3-129138	1.5A Circuit Breaker		230110-3	413A & 426A	39	35-54742	5/16-18 x 5/8" Long M-F Hex Head Whiz-Lock Screw
13	1-227360	3.5A Circuit Breaker		230110-4	614A & 628A	Order: 419247 for complete Card Cage Assembly (specify serial no.)		
14	2-227818	Card Guide	20	<u>Wiring Harness Assembly</u>				
15	<u>Mother Board Assembly</u>			230113-1	311A & 322A			
	419149-1	110 Volt (All Except 628A-R-EB)		230113-2	312A, 324A & 426A-REB			
	419149-2	220 Volt (All Except 628A-R-EB)	21	1-132468	Label			
	420540-1	628A-R-EB	22	2-228671	#10-24 Capped Washer Lock Nut			
			23	1-229652	Plastic Rivet			
			24	1-226445	Warning Label			
			25	1-130404	Warning Label			

3-741310

TCS CARD CAGE ASSEMBLY

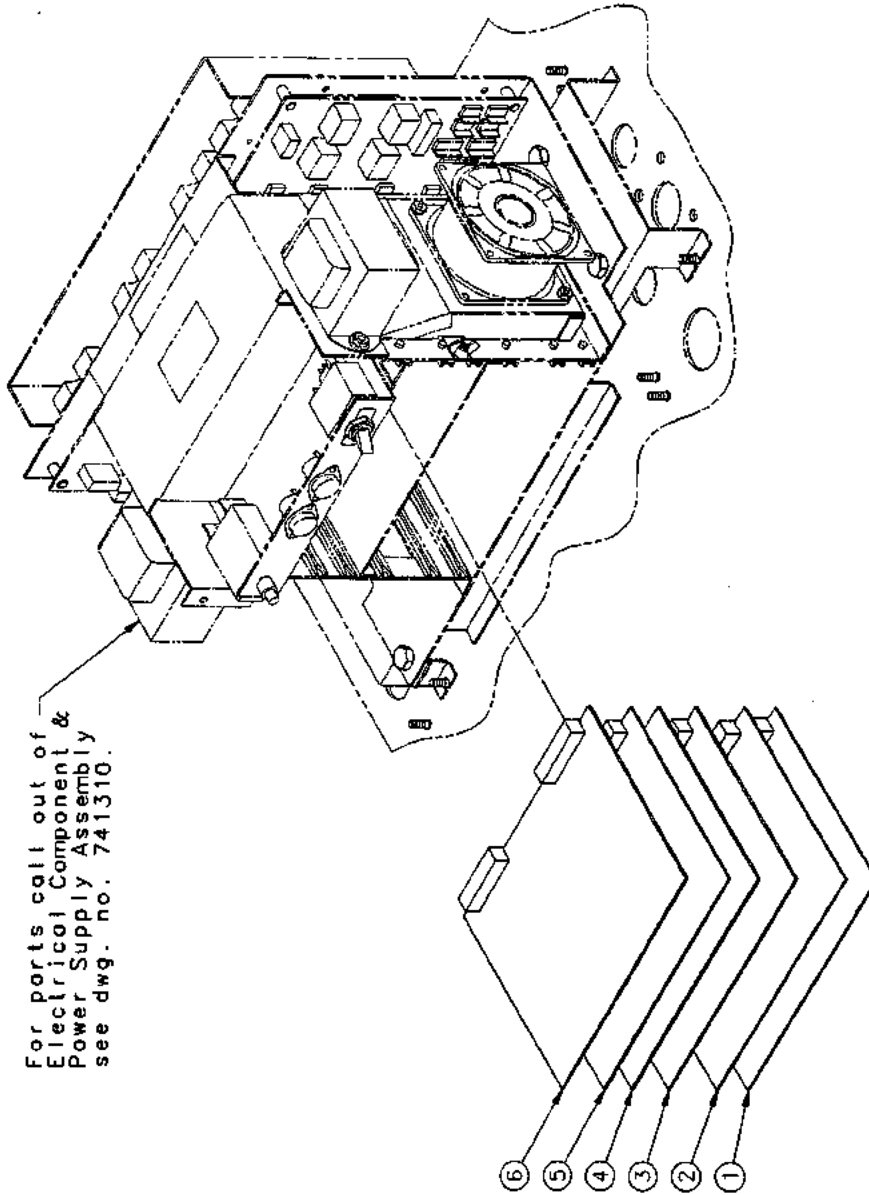

1-741527

TCS CARD CAGE ASSEMBLY

ITEM NO.	PART NO.	DESCRIPTION	ITEM NO.	PART NO.	DESCRIPTION
	<u>Models: 311A, 322A, 311A-R & 322A-R</u>			<u>Models: 312A-R & 324A-R (Taiwan)</u>	
1	417815-2	Computer Board Assembly	1	417815-6	Computer Board Assembly
2	420760-1	Interface Board Assembly	2	420760-1	Interface Board Assembly
3	<u>Multiplex Board Assembly</u>		3	417333-4	Multiplex Board Assembly
	417333-4	Without MaxVac	4	419175-3	Switch Light Control Assembly
	421420-2	MaxVac	6	420333-5	Relay Board Assy.(Fully Populated)
4	419175-3	Switch Light Control Assembly		<u>Models: 312A-R & 324A-R (220 Volt United Kingdom & A)</u>	
6	420322-6	Relay Board Assy.(Half Populated)	1	417815-2	Computer Board Assembly
	<u>Models: 312A, 324A, 312A-R & 324A-R</u>		2	420760-1	Interface Board Assembly
1	417815-2	Computer Board Assembly	3	<u>Board Assembly</u>	
2	420760-1	Interface Board Assembly		417333-4	Multiplex (220 Volt United Kingdom - A)
3	<u>Multiplex Board Assembly</u>			419844-1	Jumper (220 Volt United Kingdom)
	417333-4	Without MaxVac	6	420322-5	Relay Board Assy. (Fully Populated)
	421420-2	MaxVac		<u>Models: 312A-R & 324A-R (220 Volt United Kingdom - B)</u>	
4	419175-3	Switch Light Control Assembly	1	417815-2	Computer Board Assembly
6	420333-5	Relay Board Assy.(Fully Populated)	2	420760-1	Interface Board Assembly
	<u>Models: 312A-B & 324A-B</u>		3	417333-4	Multiplex Board Assembly
1	417815-13	Computer Board Assembly			
2	420760-1	Interface Board Assembly			
3	419700-2	Multiplex Board Assembly			
4	419175-3	Switch Light Control Assembly			
6	420322-5	Relay Board Assy.(Fully Populated)			

TCS CARD CAGE ASSEMBLY (continued)

8-24

ITEM NO.	PART NO.	DESCRIPTION	ITEM NO.	PART NO.	DESCRIPTION
<u>Models: 411A-R & 422A-R</u>			<u>Models: 413A-B & 426A-B</u>		
1	417815-10	Computer Board Assembly	1	417815-13	Computer Board Assembly
2	420760-2	Interface Board Assembly	2	420760-2	Interface Board Assembly
3	<u>Multiplex Board Assembly</u>		3	419700-2	Multiplex Board Assembly
	417333-4	Without MaxVac	4	419175-3	Switch Light Control Assembly
	421420-2	MaxVac	5	420322-5	Relay Board Assy.(Fully Populated)
4	419175-3	Switch Light Control Assembly	6	420322-6	Relay Board Assy.(Half Populated)
5	420322-6	Relay Board Assy.(Half Populated)	<u>Models: 413A-R & 426A-R (Taiwan)</u>		
6	420322-5	Relay Board Assy.(Fully Populated)	1	417815-6	Computer Board Assembly
<u>Models: 413A, 426A, 413A-R & 426A-R</u>			2	420760-2	Interface Board Assembly
1	Computer Board Assembly	<i>CPU Boards</i>	3	417333-4	Multiplex Board Assembly
	417815-2	No DPT	4	419175-3	Switch Light Control Assembly
	421124-4	Expanded (DPT)	5	420322-6	Relay Board Assy.(Half Populated)
2	<u>Interface Board Assembly</u>		6	420322-5	Relay Board Assy.(Fully Populated)
	420760-2	No DPT	<u>Models: 413A-REB & 426A-REB</u>		
	420760-3	DPT	1	421124-2	Expanded Computer Board Assembly
3	<u>Multiplex Board Assembly</u>		2	420760-1	Interface Board Assembly
	417333-4	Without MaxVac	3	<u>Blend Control Board Assembly</u>	
	421420-2	MaxVac		420170-1	Without MaxVac
4	419175-3	Switch Light Control Assembly		421588-1	MaxVac
5	420322-6	Relay Board Assy.(Half Populated)	4	419175-3	Switch Light Control Assembly
6	420322-5	Relay Board Assy.(Fully Populated)	5	420545-3	Valve Interface Board Assembly
			6	420322-3	Relay Board Assy.(Fully Populated)

TERMINAL STRIP ASSEMBLY (FOR ALL TCS)

Item No.	Part No.	Name Of Part
1	1-131572	Jumper (2 Position)
2	3-228397	Label
3	1-228612	Terminal Strip Cover
4	2-228671	#10-24 Capped Washer Locknut
5	1-228680	Terminal Strip
6	1-317654	Terminal Strip Bracket
7	98-50001	#6-32 X 5/8 Lg. Rd. Hd. Mach Screw
8	03-50211	#6-32 Hex Nut
9	03-50761	#6 Shakeproof Lockwasher

(Ref.) Barrier Plate Weld Assy.

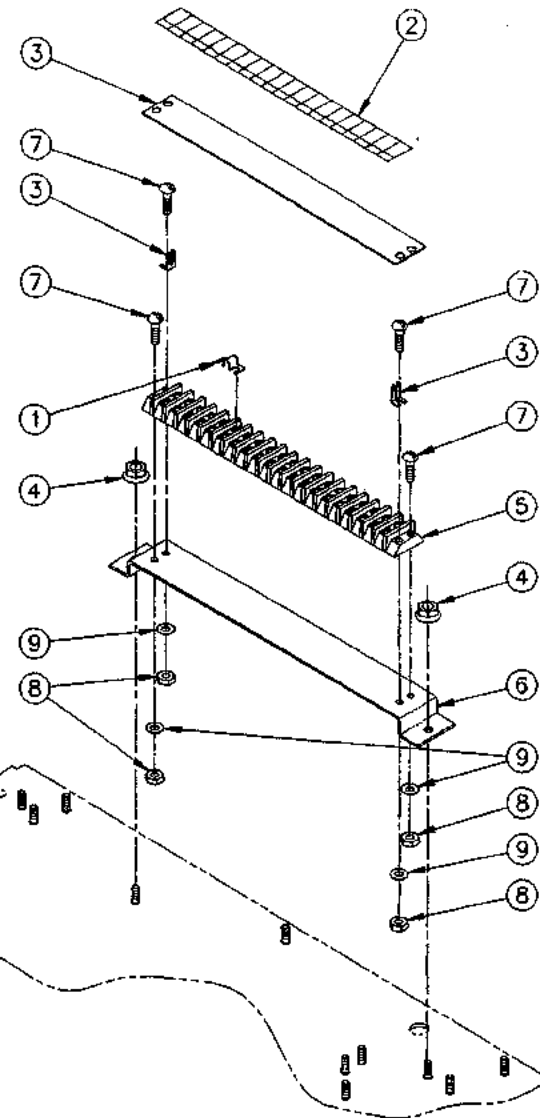

1-741430

TCS/TCSA Dispenser Parts Manual
 Form 4576A Version 1.0
 Tokheim Corporation February 1996

MANAGER'S KEYLOCK (TCS NON "A")
 (MOUNTED ON SIDE OF ENCLOSURE)

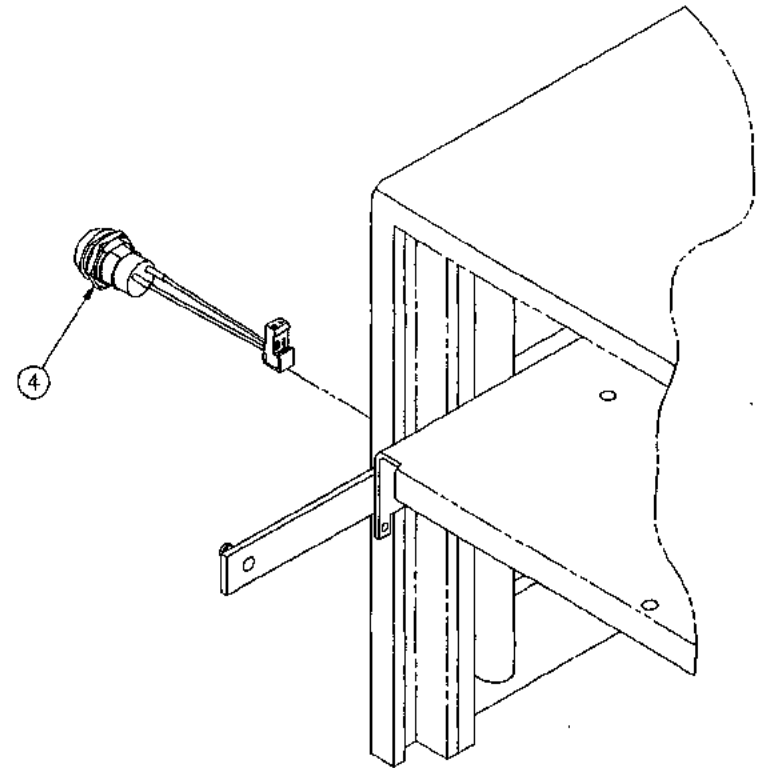
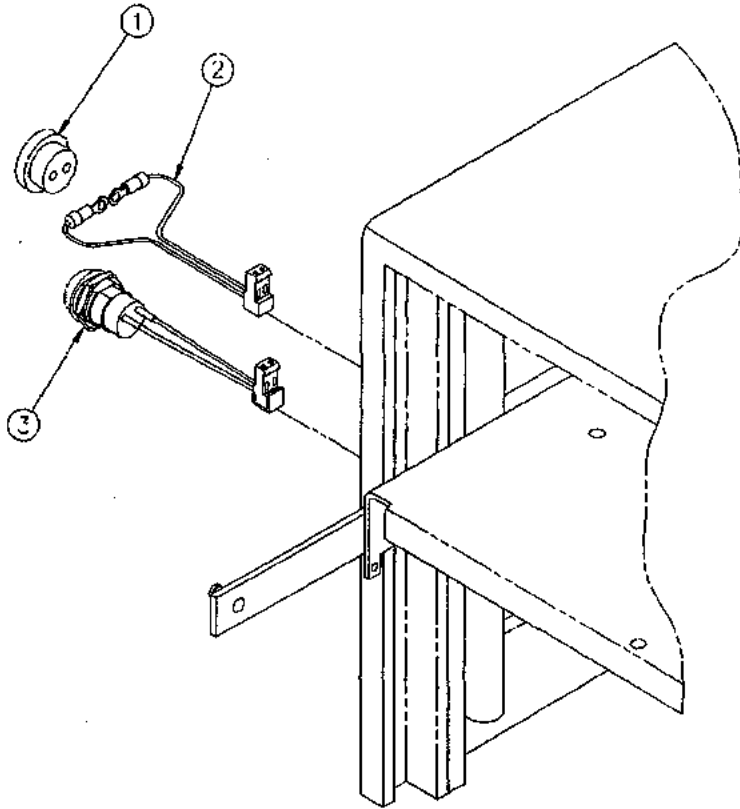

Item No.	Part No.	Name Of Part
1	3-227937	Sealed Touch Switch
2	228907-1	Wire Harness Assembly
3	228922-1	Switch Lock Assembly
4	1-229023	Switch Lock
	2-229023	Key

BARRIER CONDUIT ASSY. FOR TCS

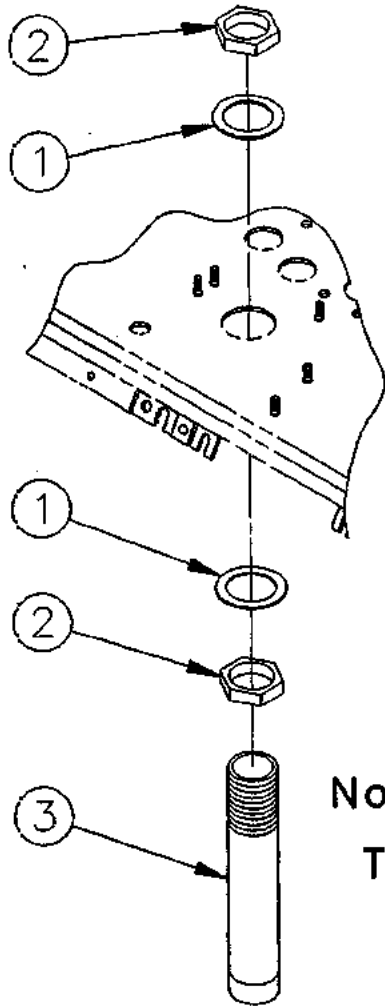

Item No.	Part No.	Name Of Part
1	1-131463	Conduit Washer
2	1-131470	Hex Locknut
3	418150-1	Barrier Conduit Assy. (All 324, 426 & 628) (15 Total Wires)
	<i>Hoses 152 A&B</i>	
	<i>Hoses A35B3</i>	
	418150-2	Barrier Conduit Assy. (All 322, 426 & 614) (8 Total Wires)
	<i>426</i>	
	418150-3	Barrier Conduit Assy. (All 312, 413 & 426) (8 Total Wires)
	418150-4	Barrier Conduit Assy. (All 311 & 413) (5 Total Wires)

Note:

Total wires = combined total
of top & bottom wires.

2-72207



Notes

322A-R-B3/B5 CARD CAGE ASSEMBLY

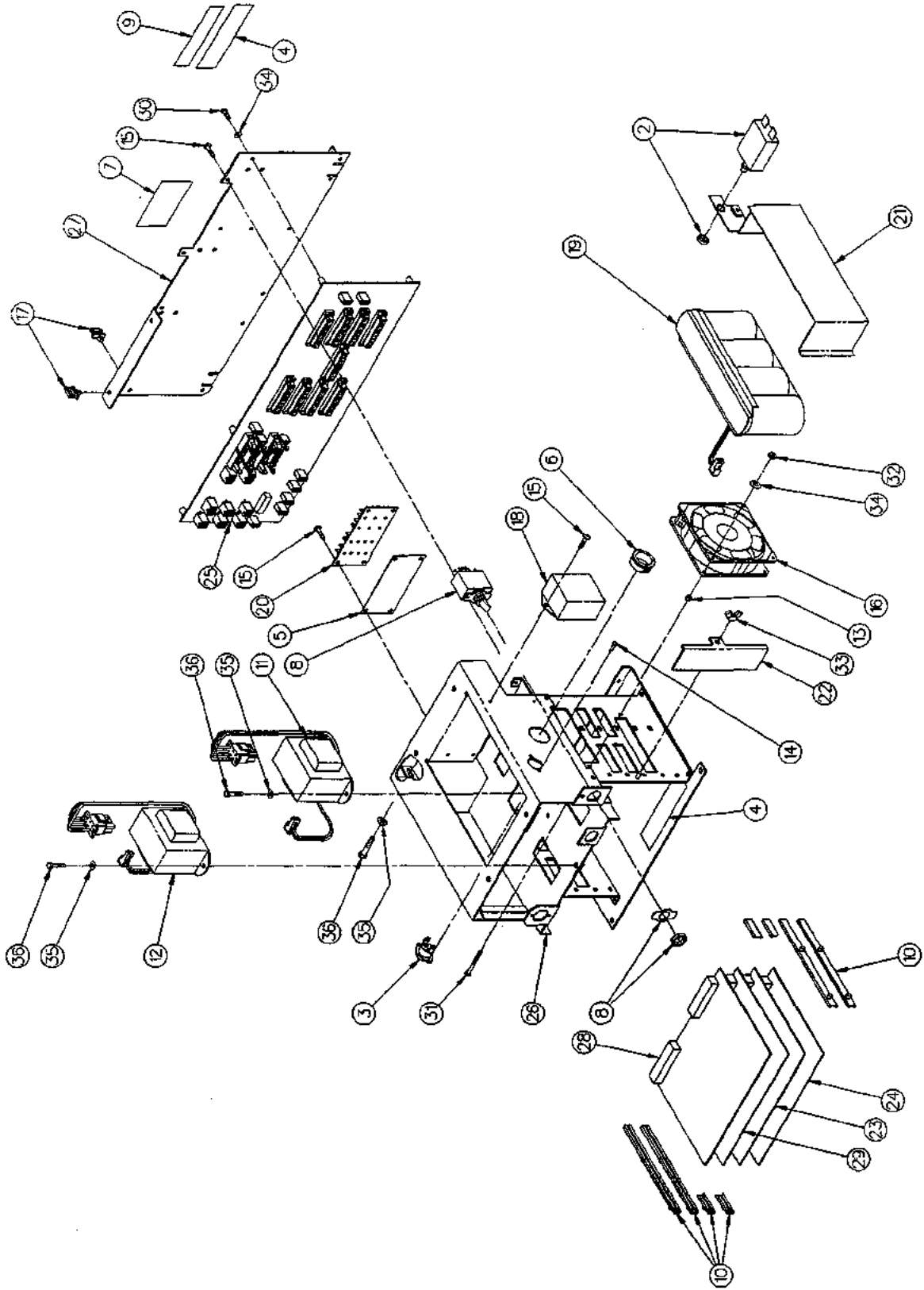

2-741485

322A-R-B3/B5 CARD CAGE ASSEMBLY

ITEM NO.	PART NO.	DESCRIPTION	ITEM NO.	PART NO.	DESCRIPTION
1	1-128725	Cable Tie	23		<u>Blend Controller Board Assembly</u>
2	3-129138	Breaker (1.5 Amp)		420170-1	Without MaxVac
3	3-130217	Thermostat		421588-1	MaxVac
4	1-130404	Warning Label	24	420545-2	Valve Interface Board Assembly
5	1-132449	Terminal Strip Cover	25	420606-1	Mother Board Assembly
6	3-225460	Bushing	26	420662-1	Card Cage Weld Assembly
7	1-226445	Warning Label	27	1-420691	Mother Board Bracket
8	1-227360	Breaker (3.5 Amp)	28	420760-1	Interface Board Assembly
9	1-227816	Label	29	421124-3	Expanded Computer Board Assembly
10	2-227818	Card Guide	30	88-50001	#6-32 x 1/4" Long Round Head Machine Screw
11	227887-3	Transformer Assembly (T-1)	31	110-50001	#6-32 x 1-1/2" Long Round Head Machine Screw
12	227887-4	Transformer Assembly (T-2)	32	03-50211	#6-32 Hex Nut33 03-50381 #8-32 Wing Nut
13	5-229606	Spacer	34	03-50761	#6 Shakeproof Lockwasher
14	1-229652	Plastic Rivet	35	04-50761	#8 Shakeproof Lockwasher
15	1-230689	#6 Self Tapping Screw	36	166-52851	#8-32 x 1/4" Long Hex Head Machine Screw
16	<u>Fan</u>		<p><u>For complete Card Cage Assembly order: 420615-1</u></p> <hr style="border: 1px solid black;"/> <p style="text-align: right;">2-741485</p>		
	1-230737	115 Volt			
	2-230737	230 Volt 50/60Hz			
17	1-230998	Wire Saddle			
18	5-315628	Filter			
19	318349- 5 ⁴	Battery Assembly			
20	1-318739	Terminal Strip			
21	319109-1	Battery Retainer Weld Assembly			
22	2-319232	Card Retainer			

TCS/TCSA Dispenser Parts Manual
Form 4576A Version 1.0
Tokheim Corporation February 1996

POWER SUPPLY & CARD CAGE ASSEMBLY

(MODEL 322A-R-B5)

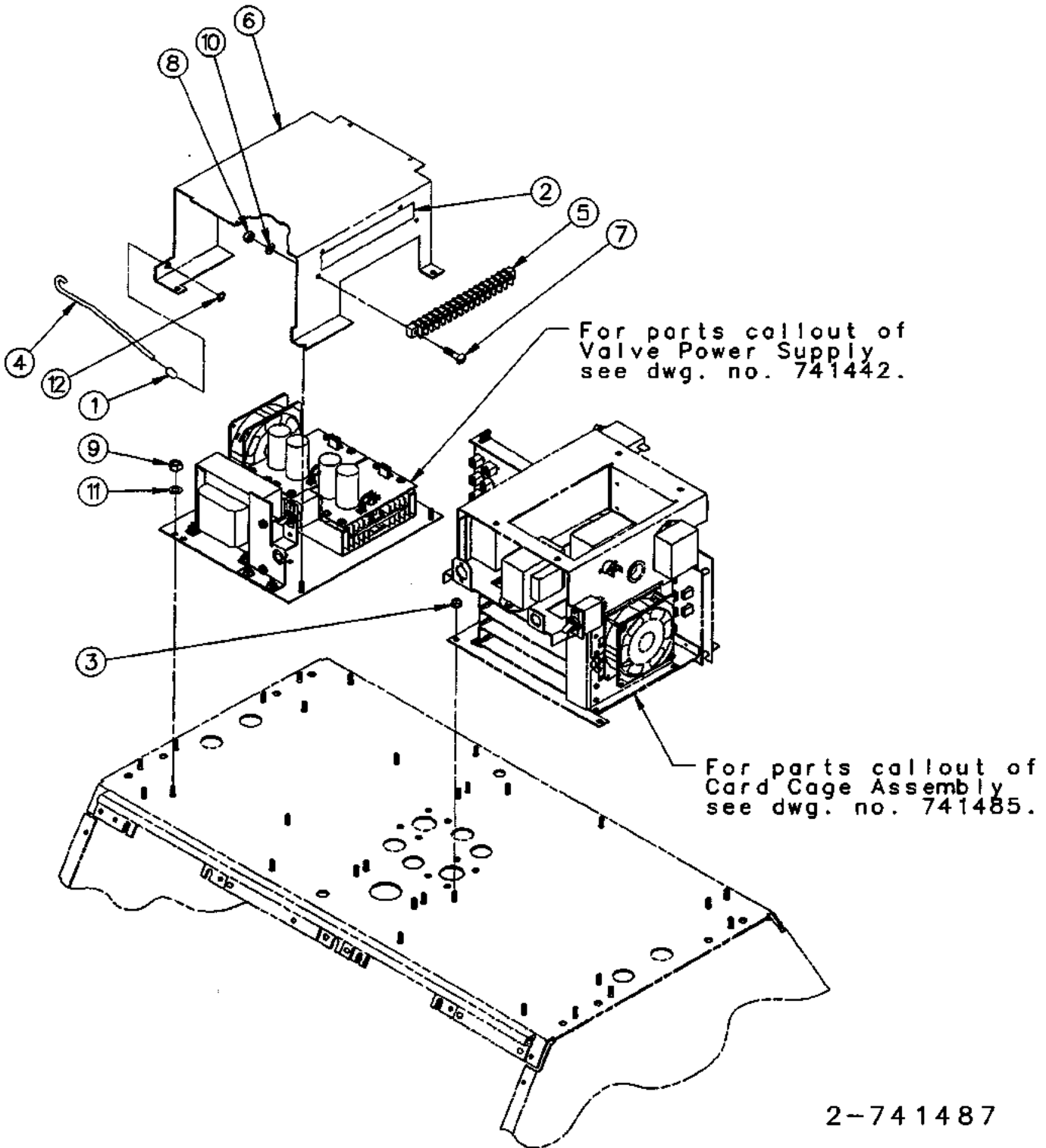

POWER SUPPLY & CARD CAGE ASSEMBLY (MODEL 322A-R-B5)

ITEM NO.	PART NO.	DESCRIPTION
1	1-132459	End Cap
2	3-228397	Label
3	2-228671	#10-24 Capped Washer
4	3-228674	Prop Rod
5	1-319191	Terminal Strip
6	2-420657	Power Supply Base
7	100-50001	#6-32 x 3/4" Long Round Head Machine Screw
8	03-50211	#6-32 Hex Nut
9	05-50211	#10-24 Hex Nut
10	21-50761	#6 Shakeproof Lockwasher
11	23-50761	#10 Shakeproof Lockwasher
12	05-52532	Truarc Retaining Ring

Reference: 420733 Trim Assembly

2-741487

WIRING SCHEMATIC FOR DISPENSER MODEL 300, 400, 600 SERIES (NON-A)

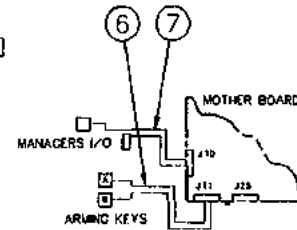
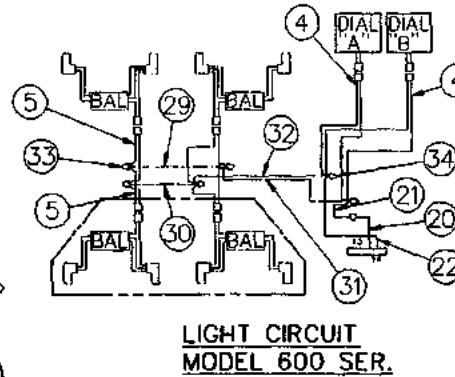
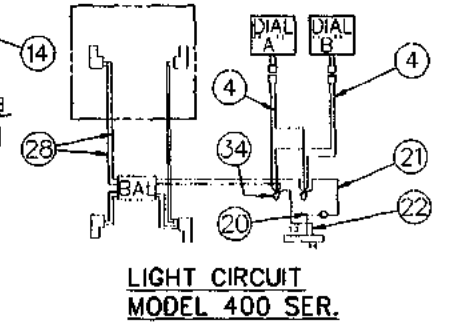
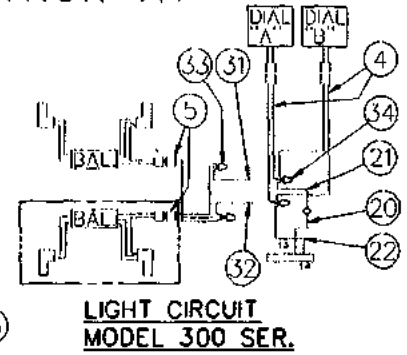
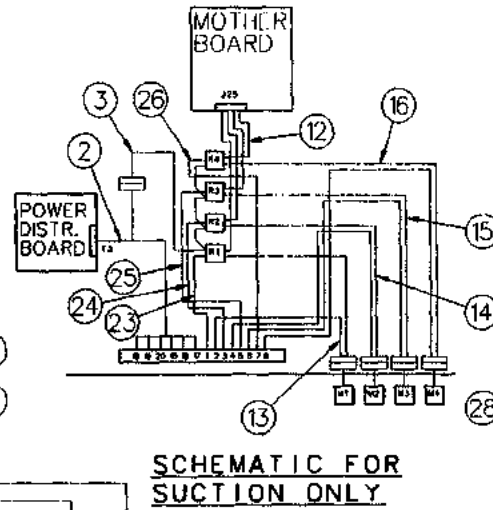
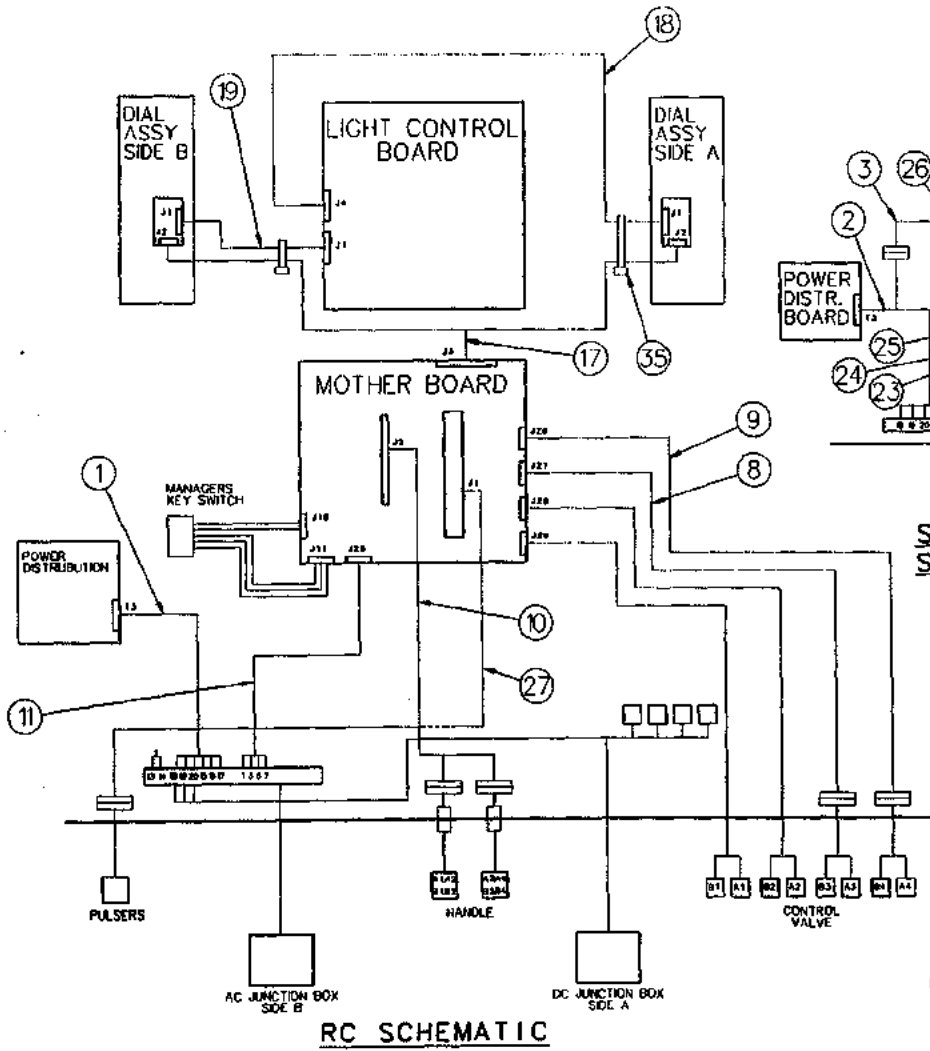

DISPENSER WIRE SCHEMATIC - For TCS "Non-A" series

Models 300, 400, 600 Series

3-741285
1 of 1

ITEM NO.	PART NO.	DESCRIPTION	ITEM NO.	PART NO.	DESCRIPTION
1	228396-1	Wire Harness Assembly	16	317665-5	Wire Harness Assy.(60" Only)
2	228396-2	Wire Harness Assembly	17	<u>Wire Harness Assemblies</u>	
3	<u>Wire Harness Assemblies</u>			317697-1	Dials on 2 Sides
	228679-1	614 & 628		317697-2	Dials on 1 Sides
	228679-2	413 & 426	18	317698-1	Wire Harness Assembly
	228679-3	312 & 324	19	317698-2	Wire Harness Assembly
	228679-4	311 & 322	20	416806-35	Lead Assembly
4	228903-1	Wire Harness Assembly	21	416806-36	Lead Assembly
5	228903-2	Wire Harness Assembly	22	416806-37	Lead Assembly
6	317460-1	Wire Harness Assembly	23	416806-38	Lead Assembly
7	317460-2	Wire Harness Assembly	24	416806-39	Lead Assembly
8	<u>Wire Harness Assemblies</u>		25	416806-40	Lead Assembly
	317470-1	45"	26	416806-41	Lead Assembly
	317470-2	60"	27	<u>Wire Harness Assemblies</u>	
9	317470-2	Wire Harness Assy.(60")		418202-1	30"
10	<u>Wire Harness Assemblies</u>			418202-2	45"
	317475-1	30"		418202-3	60"
	317475-2	60"	28	015-548924-09	#18 Yellow Conductor
	317475-3	45"	29	016-548909-09	#18 Black Conductor
11	317479-1	Wire Harness Assy.(RC Only)	30	016-548904-09	#18 White Conductor
12	<u>Wire Harness Assemblies</u>		31	028-548909-09	#18 Black Conductor
	317479-2	311 & 322	32	028-548904-09	#18 White Conductor
	317479-3	312 & 324	33	1-129223	Wire Connector
	317479-4	413 & 426		1-127473	Wire Connector (311, 312 & 614)
	317479-5	614 & 628	34	1-127473	Wire Connector
13	317665-1	Wire Harness Assembly	35	2-128725	Cable Tie
14	317665-2	Wire Harness Assembly			
15	<u>Wire Harness Assemblies</u>				
	317665-3	45"			
	317665-4	60"			

3-741285

WIRING SCHEMATIC FOR DISPENSER MODEL 300A, 400A & 600A SERIES

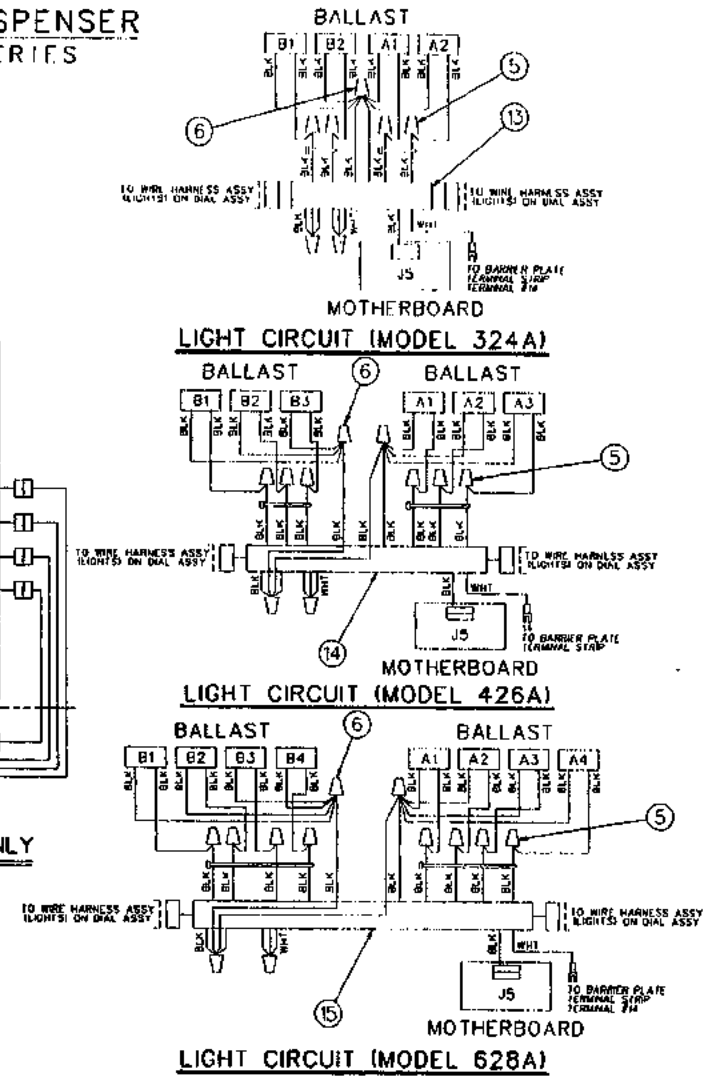
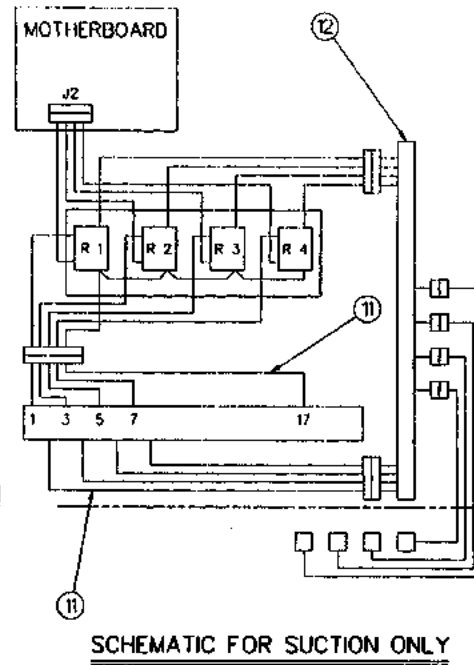
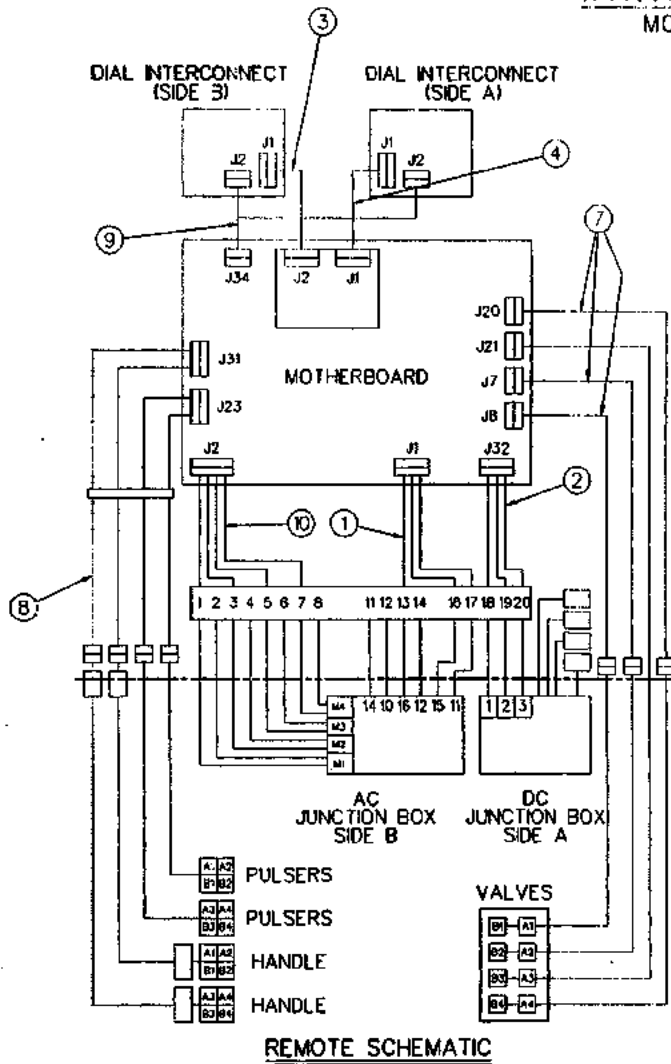

2-741327

DISPENSER WIRE SCHEMATIC

Models 300A, 400A, & 600A Series

ITEM NO.	PART NO.	DESCRIPTION	ITEM NO.	PART NO.	DESCRIPTION
1	229684-1	Wire Harness Assembly	9		<u>Wire Harness Assemblies - Continued</u>
2	229683-1	Wire Harness Assembly		318261-4	413A
3		<u>Wire Harness Assemblies</u>		318261-5	628A
	318262-2	322A & 324A		318261-6	614A
	318262-4	426A	10		<u>Wire Harness Assemblies</u>
	318262-6	628A		230124-1	311AR & 322AR
4		<u>Wire Harness Assemblies</u>		230124-2	312AR & 324AR
	318262-1	30"A		230124-3	413AR & 426AR
	318262-3	45"A		230124-4	614AR & 628AR
	318262-5	60"A	11		<u>Wire Harness Assemblies</u>
5	1-129223	Wire Connector		229698-1	311A & 322A
6	1-131360	Wire Connector		229698-2	312A & 324A
7	318350-1	Wire Harness Assy. (45"A & 60"A)		229698-3	413A & 426A
				229698-4	614A & 628A
8		<u>Wire Harness Assemblies</u>	12		<u>Wire Harness Assemblies</u>
	419617-1	30"A		419626-1	311A & 322A
	419617-2	45"A		419626-2	312A & 324A
	419617-3	60"A		419626-3	413A & 426A
9		<u>Wire Harness Assemblies</u>		419626-4	614A & 628A
	318261-1	322A & 324A	13	318362-1	Wire Harness Assembly (30"A)
	318261-2	311A & 312A	14	318362-2	Wire Harness Assembly (45"A)
	318261-3	426A	15	318362-3	Wire Harness Assembly (60"A)

WIRING SCHEMATIC FOR 30" 3 & 5 PRODUCT DISPENSER

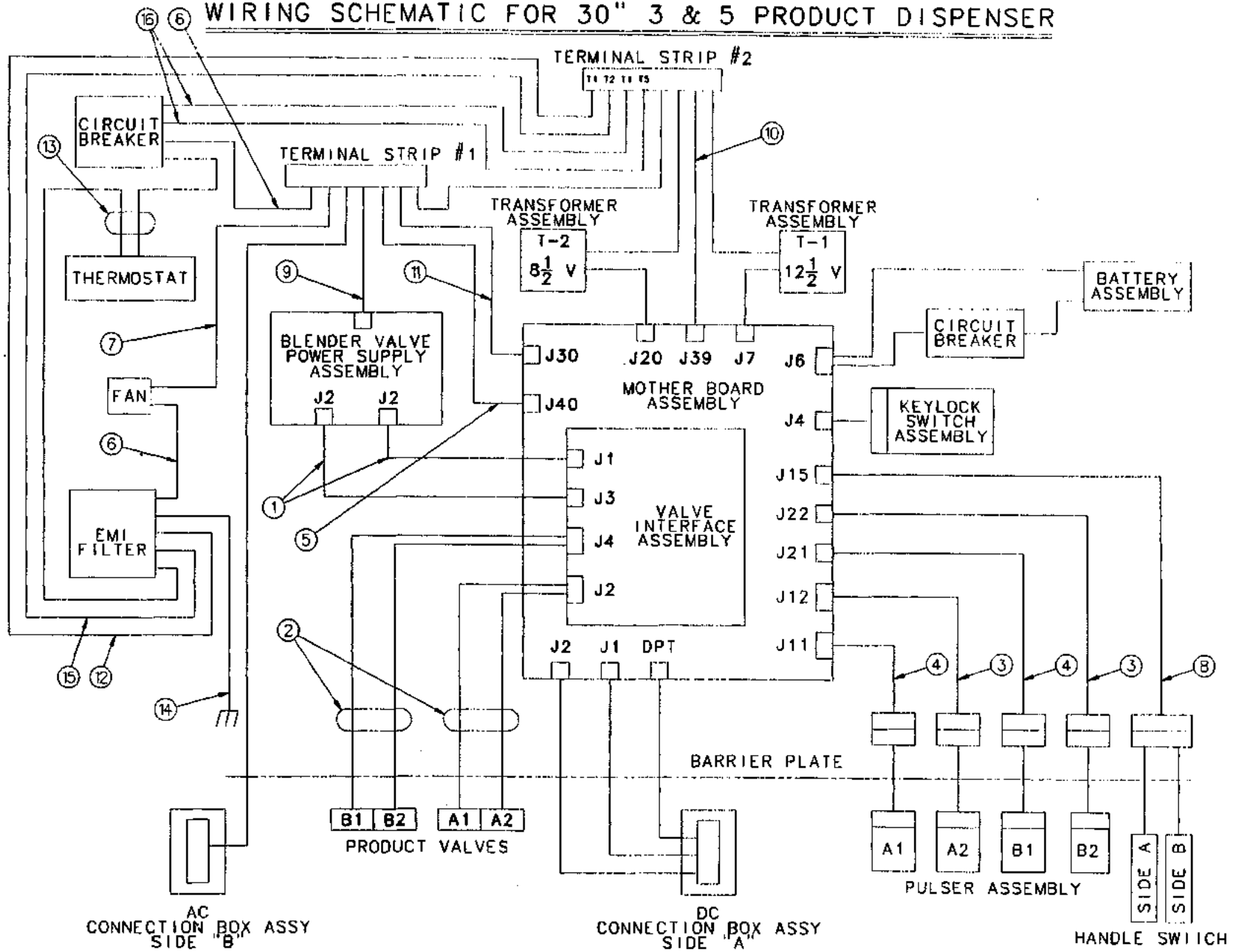

1-741500

1 of 1

WIRING SCHEMATIC

For 30" 3 & 5 PRODUCT DISPENSER

ITEM NO.	PART NO.	DESCRIPTION	ITEM NO.	PART NO.	DESCRIPTION
1	230682-1	Blender Valve Power Supply Harness Assembly (To Valve Interface)	12	420165-11	EMI Filter Harness Assembly (To T1 On Terminal Strip #2)
2	230683-2	Product Harness Assembly	13	420165-12	Thermostat Harness Assembly
3	230934-1	Pulser Harness Assembly (A2 & B2)	14	420165-32	EMI Filter Harness Assembly (To Ground)
4	230934-2	Pulser Harness Assembly (A1 & B1)	15	420165-34	EMI Filter Harness Assembly (To T2 On Terminal Strip #2)
5	230937-1	Wire Harness Assembly (Mother Board To Terminal Strip #2)	16	420165-49	Circuit Breaker Harness Assembly (To Terminal Strip #2)
6	231002-1	Circuit Breaker Harness Assembly (To Terminal Strip #1)			
7	231002-2	Fan Harness Assembly (To Terminal Strip #1)			
8	231012-1	Handle Switch Harness Assembly			
9	318883-3	Blender Valve Power Supply Harness Assembly (To Terminal Strip #1)			
10	319194-1	Wire Harness Assembly (Mother Board J39 To Terminal Strip #2)			
11	319194-2	Wire Harness Assembly (Mother Board J30 To Terminal Strip #1)			

1-741500

WIRING SCHEMATIC FOR DISPENSER (MODEL 411A & 422A)

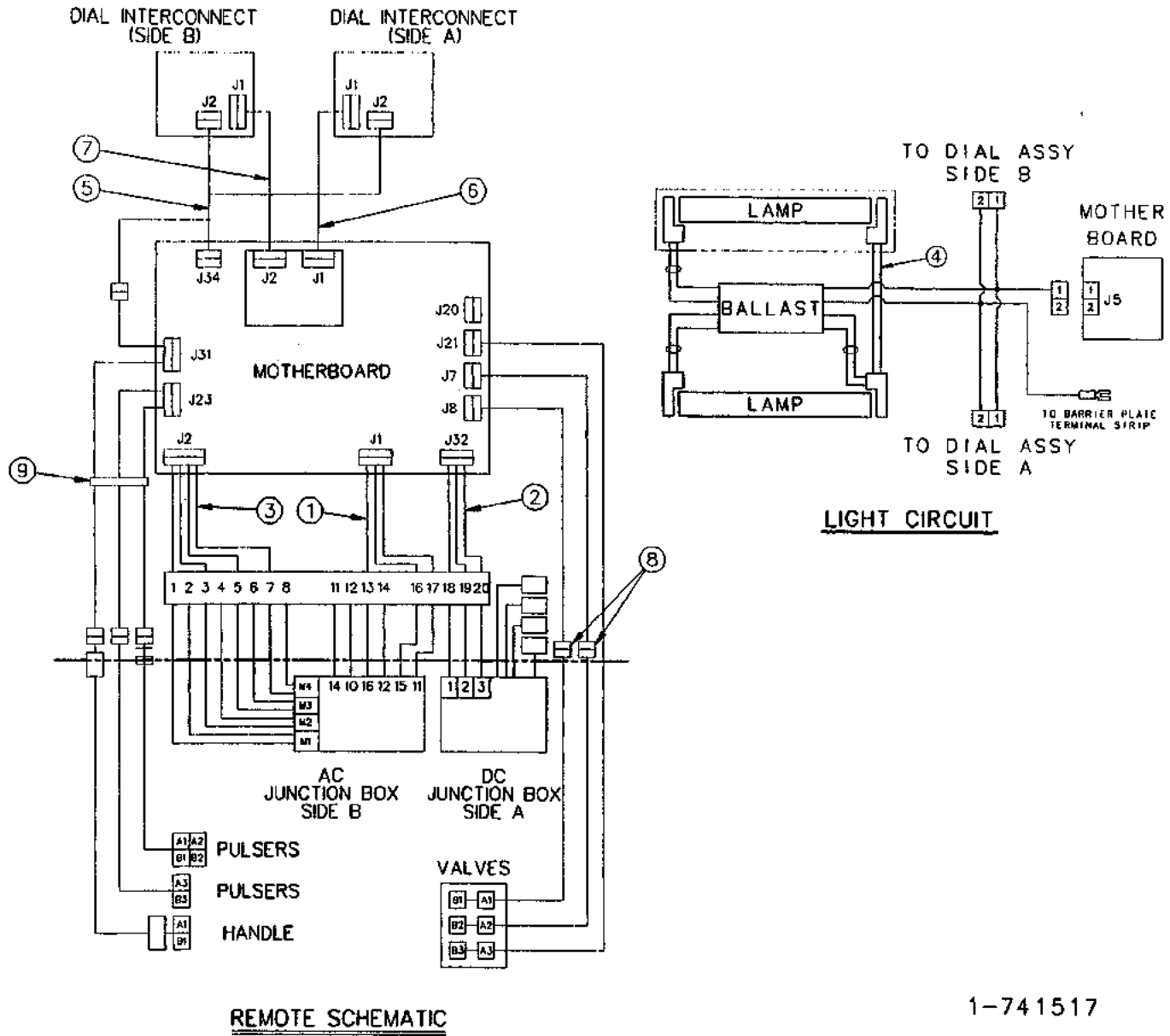

WIRING SCHEMATIC FOR DISPENSER Model 411A & 422A

1-741517
1 of 1

ITEM NO.	PART NO.	DESCRIPTION
1	229683-1	Wire Harness Assembly
2	229684-1	Wire Harness Assembly
3	230124-3	Wire Harness Assembly
4	230819-1	Wire Harness Assembly
5	<u>Wire Harness Assembly</u>	
	318261-3	422A
	318261-4	411A
6	318262-3	Wire Harness Assembly
7	318262-4	Wire Harness Assembly
8	318350-1	Wire Harness Assembly
9	419617-2	Wire Harness Assembly

1-741517

MaxVac WIRING SCHEMATIC

(All Models Except 30" Variable Blenders)

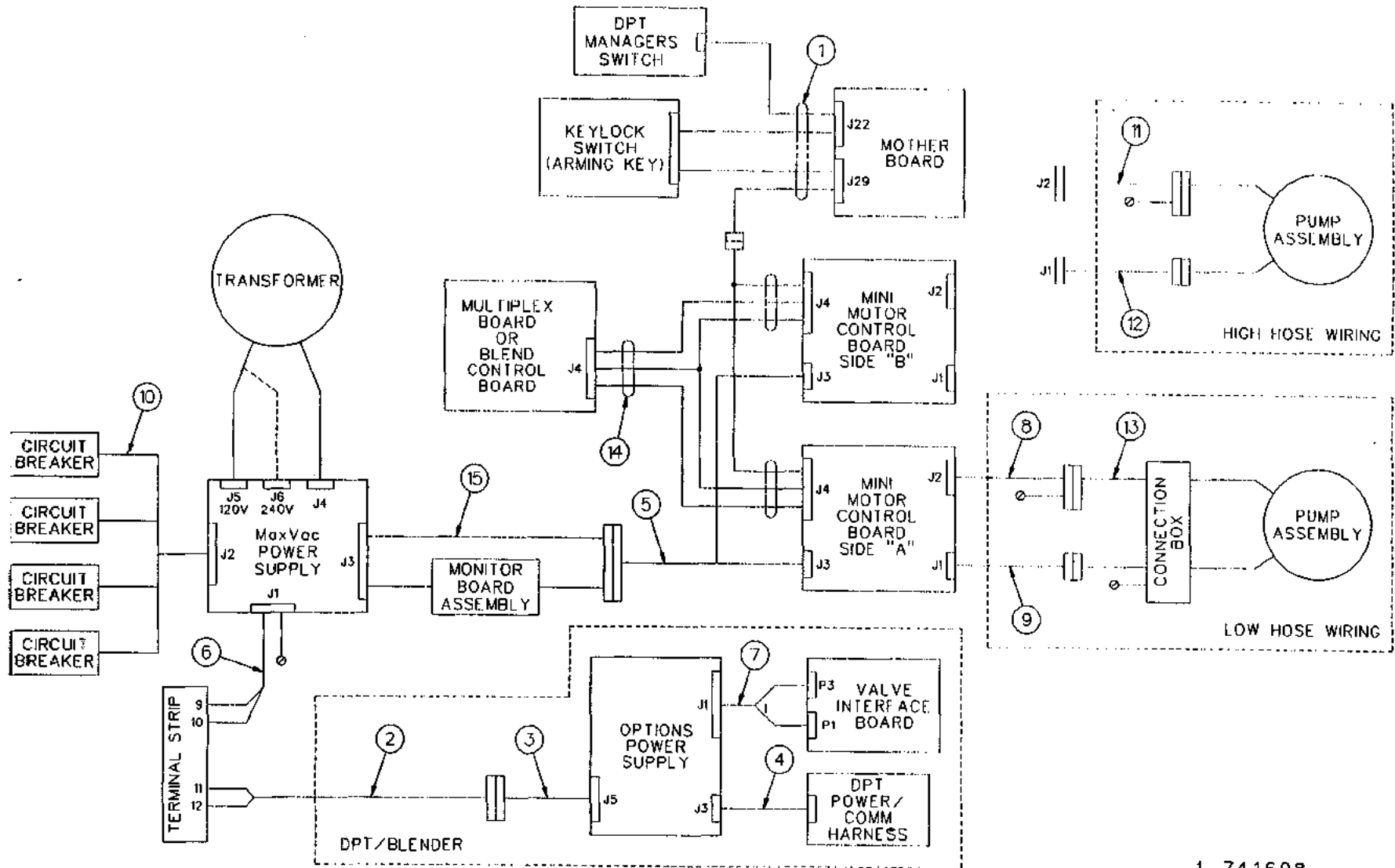

MaxVac WIRING SCHEMATIC

(All TCS "A" Models Except 30" Variable Blender)

ITEM NO.	PART NO.	DESCRIPTION	ITEM NO.	PART NO.	DESCRIPTION
1	230682-1	Blender Valve Power Supply Harness Assembly (To Valve Interface)	14	<u>Reset/Pulser Harness Assembly</u>	
1	230187-3	Keylock Switch Harness Assembly	319776-1	411/22A-R, 413/26A-R & 614/28A R	
2	232306-1	AC Terminal Strip Harness Assembly	319776-2	413/26A-REB & 614/28A-REB	
3	232307-1	Main AC Option Power Supply Harness Assembly	15	421646-1	Monitor Board Assembly
4	232308-1	DPT DC Power Harness Assembly	<u>Reference:</u>		
5	232309-1	DC Power Harness Assembly	<u>Vapor Recovery Kits</u>		
6	232310-1	Main AC Harness Assembly	319729	400A	
7	232312-1	Blend DC Power Harness Assembly	319775	H400A	
8	232313-1	Motor Pump Harness Assembly	<u>System Wiring Diagram 421592</u>		
9	232314-1	Motor Pump Harness Assy. (Sensor)	<hr/>		
10	319500-2	Circuit Breaker Harness Assembly	1-741608		
11	<u>Motor Pump Harness Assembly (Power)</u>				
	319685-5	45"			
	319685-7	60"			
12	<u>Motor Pump Harness Assembly (Sensor)</u>				
	319685-6	45"			
	319685-8	60"			
13	319774-1	Conduit Barrier Harness Assembly			

MaxVac WIRING SCHEMATIC (TCS "A" 30" Variable Blender)

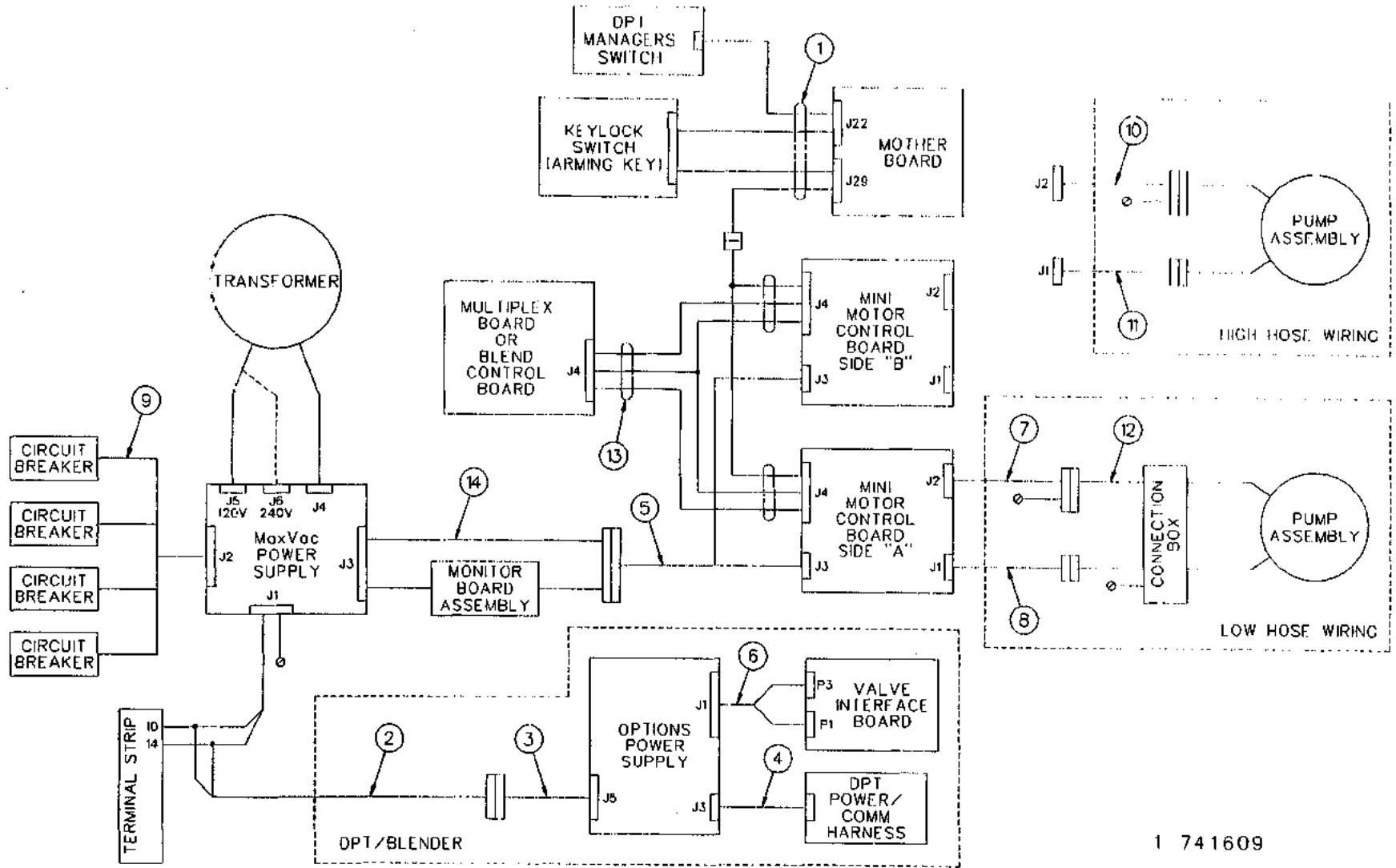

1 741609

**MaxVac WIRING SCHEMATIC
(TCS "A" 30" Variable Blender)**

ITEM NO.	PART NO.	DESCRIPTION	ITEM NO.	PART NO.	DESCRIPTION
1	231011-2	Keylock Switch Harness Assembly	11	319685-4	Motor Pump Harness Assembly (Sensor)
2	232306-2	AC Terminal Strip Harness Assembly	12	319774-1	Conduit Barrier Harness Assembly
3	232307-1	Main AC Option Power Supply Harness Assembly	13	319776-2	Reset/Pulser Harness Assembly
4	232308-1	DPT DC Power Harness Assembly	14	421646-1	Monitor Board Assembly
5	232309-2	DC Power Harness Assembly	<p><u>Reference:</u> <u>Vapor Recovery Kits</u> 319836 300A 319840 H300A</p> <p><u>System Wiring Diagram 421835</u></p> <hr/> <p style="text-align: right;">1-741609</p>		
6	232312-1	Blend DC Power Harness Assembly			
7	232313-1	Motor Pump Harness Assembly			
8	232314-1	Motor Pump Harness Assembly (Sensor)			
9	319500-2	Circuit Breaker Harness Assembly			
10	319685-3	Motor Pump Harness Assembly (Power)			

TCS/TCSA Dispenser Parts Manual
Form 4578A, Version 1.0
Tollheim Corporation, February 1986

MOTOR CONTROL ASSEMBLY (400A & 600A MaxVac)

ITEM NO.	PART NO.	DESCRIPTION
1	1-128725	Cable Tie (Not Shown)
2	1-130404	Warning Label
3	1-227816	Label
4	<u>Circuit Breaker</u>	
	6-228135	2 Amp (120 Volt AC)
	11-228135	1 Amp (240 Volt AC)
5	12-228135	Circuit Breaker (0.7 Amp)
6	13-228135	Circuit Breaker (2.5 Amp)
7	2-228671	#10-24 Capped Washer Locknut
8	232309-1	DC Power Harness Assembly
9	1-232334	Support Plate
10	1-232394	Transformer Shield
11	318942-2	Transformer Assembly
12	319500-2	Circuit Breaker Harness Assembly
13	420226-2	Support Weld Assembly
14	421449-2	Motor Control Board Assembly (All Models Side "A")
15	421449-2	Motor Control Board Assembly (422A-R, 426A-R/REB & 628A-R/REB Side "B")
16	421522-1	Base Weld Assembly
17	421579-3	Power Supply Board Assembly
18	421646-1	Monitor Board Assembly
19	88-50001	#6-32 x 1/4" Long Round Head Machine Screw
20	170-50001	#8-32 x 3/8" Long Round Head Machine Screw
21	04-50211	#8-32 Hex Nut
22	09-50361	1/4-20 x 2" Long Round Head Machine Screw
23	04-50761	#8 Shakeproof Lockwasher
24	03-50762	#6 Shakeproof Lockwasher
25	01-54752	1/4-20 M-F Flange Whiz Lock Nut

For complete Circuit Breaker Harness Assembly order: (Includes Item #4, 5, 6 & 12)

319500-3	120 Volt AC
319500-4	240 Volt AC

For complete Motor Control Assembly order:

421579-1	411A-R, H413A-R/REB & H614A-R/REB
421579-2	422A-R, H426A-R/REB & H628A-R/REB

1-73967

POWER SUPPLY & MOTOR CONTROL ASSEMBLY

(300A MaxVac)

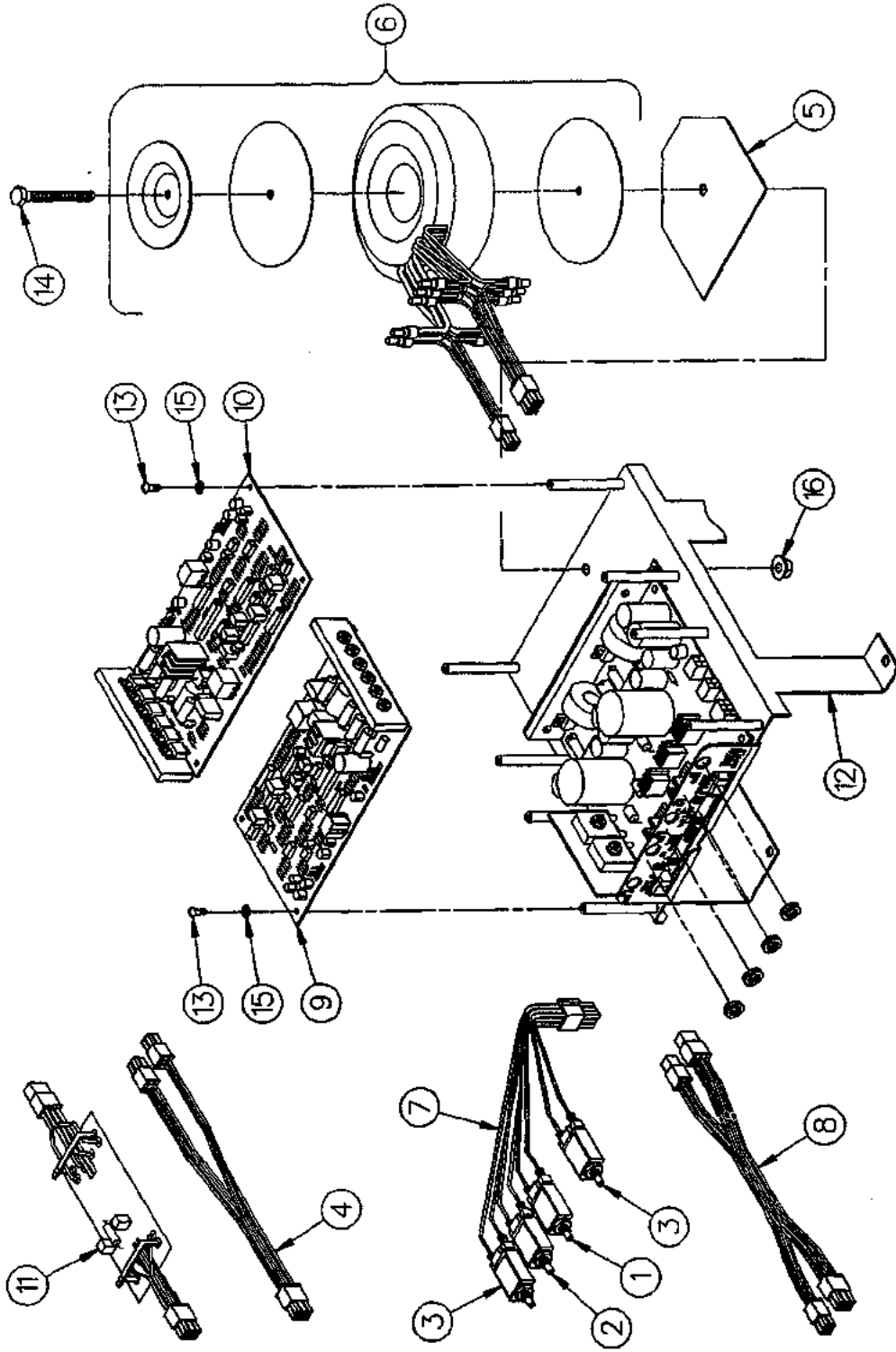

1-73970

POWER SUPPLY & MOTOR CONTROL ASSEMBLY (300A MaxVac)

1-741970
1 of 1

TCS/TCSA Dispenser Parts Manual
Form 4576A Version 1.0
Tdklein Corporation February 1995

ITEM NO.	PART NO.	DESCRIPTION	ITEM NO.	PART NO.	DESCRIPTION
1	<u>Circuit Breaker</u> 6-228135	2 Amp (120 Volt AC)	13	88-50001	#6-32 x 1/4" Long Round Head Machine Screw
	11-228135	1 Amp (240 Volt AC)	14	09-50361	1/4-20 x 2" Long Round Head Machine Screw
2	12-228135	Circuit Breaker (0.7 Amp)	15	03-50762	#6 Shakeproof Lockwasher
3	13-228135	Circuit Breaker (2.5 Amp)	16	01-54752	1/4-20 M-F Flange Whiz Lock Nut
4	232309-1	DC Power Harness Assembly	<u>For complete Circuit Breaker Harness Assembly order: (Includes Item #1, 2, 3 & 7)</u>		
5	1-232334	Support Plate	319500-3		120 Volt AC
6	318942-2	Transformer Assembly	319500-4		240 Volt AC
7	319500-2	Circuit Breaker Harness Assembly	<u>For complete Power Supply & Motor Control Assembly order:</u>		
8	319947-1	Extension Harness Assembly (311A-RB3/5 & 322A-RB3/5 Only)	421730-1		311A-R & 312A-R
9	421449-2	Mini Motor Control Board Assembly (All Models Side "A")	421730-2		322A-R & 324A-R
10	421449-2	Mini Motor Control Board Assembly (322A-R, 322A-RB3/5 & 324A-R)	421730-3		311A-RB3/5
11	421646-1	Monitor Board Assembly	421730-4		322A-RB3/5
12	<u>Power Supply & Motor Control Board Assembly</u> 421730-5	311A-R, 312A-R, 322A-R & 324A-R	<hr style="border: 1px solid black;"/>		
	421730-6	311A-RB3/5 & 322A-RB3/5	1-73970		

OPTIONS POWER SUPPLY ASSEMBLY

(300A MaxVac)

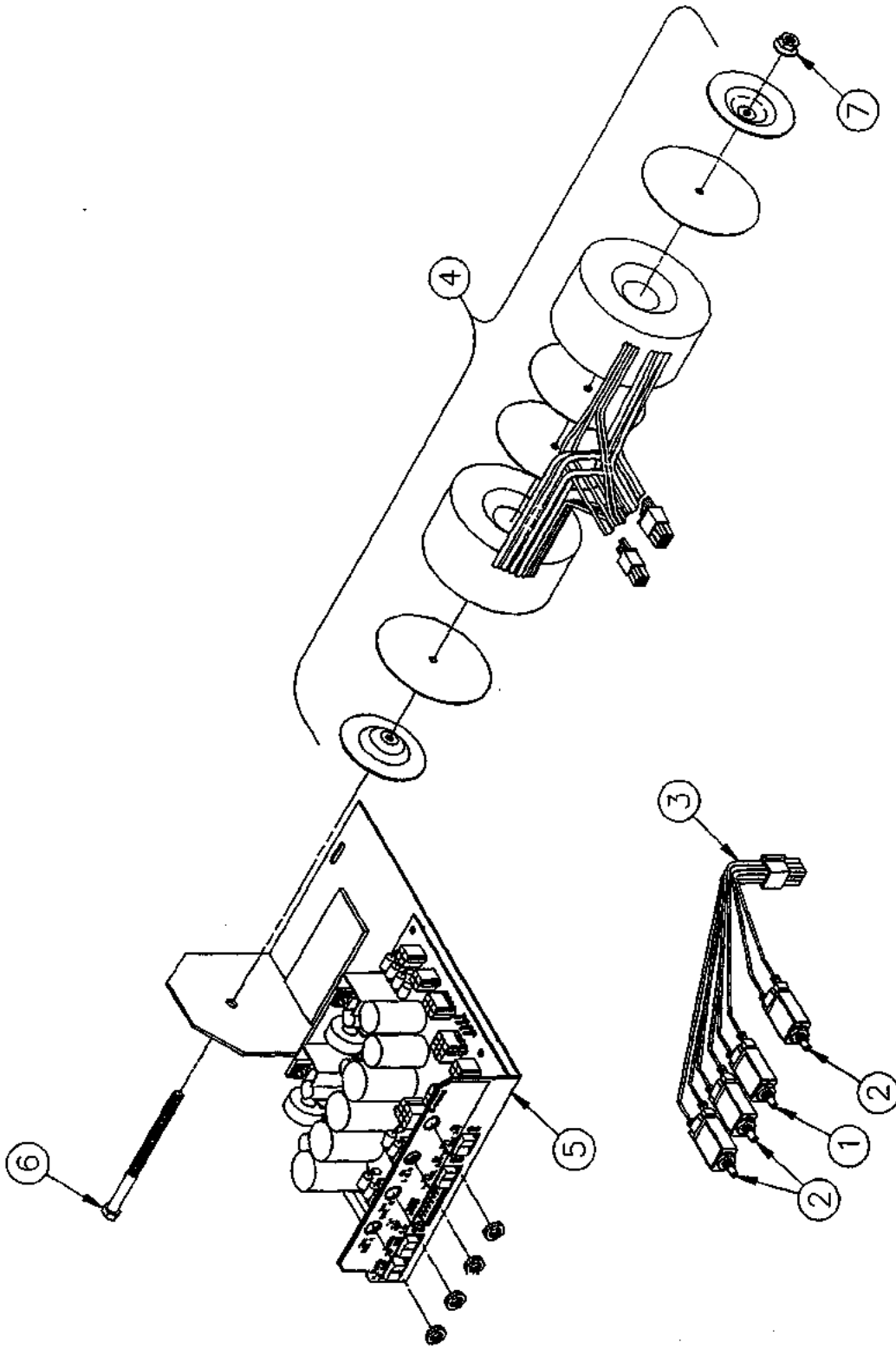

1-73969

1-73969

1 of 1

OPTIONS POWER SUPPLY ASSEMBLY (300A MAXVAC)

ITEM NO.	PART NO.	DESCRIPTION
1	6-228135	Circuit Breaker (2 Amp)
2	9-228135	Circuit Breaker (3 Amp)
3	319500-2	Circuit Breaker Harness Assembly
4	319582-1	Transformer Assembly
5	319839-2	Options Power Supply Board Assembly
6	312-50361	1/4-20 x 4" Long Hex Head Cap Screw
7	01-54752	1/4-20 M-F Flange Whiz Lock Nut

For complete Circuit Breaker Harness Assembly order:
(Includes Item #1, 2 & 3) 319500-1

For complete Options Power Supply Assembly order: 319839-1

1-73969

OPTIONS POWER SUPPLY ASSEMBLY

(400A & 600A MaxVac)

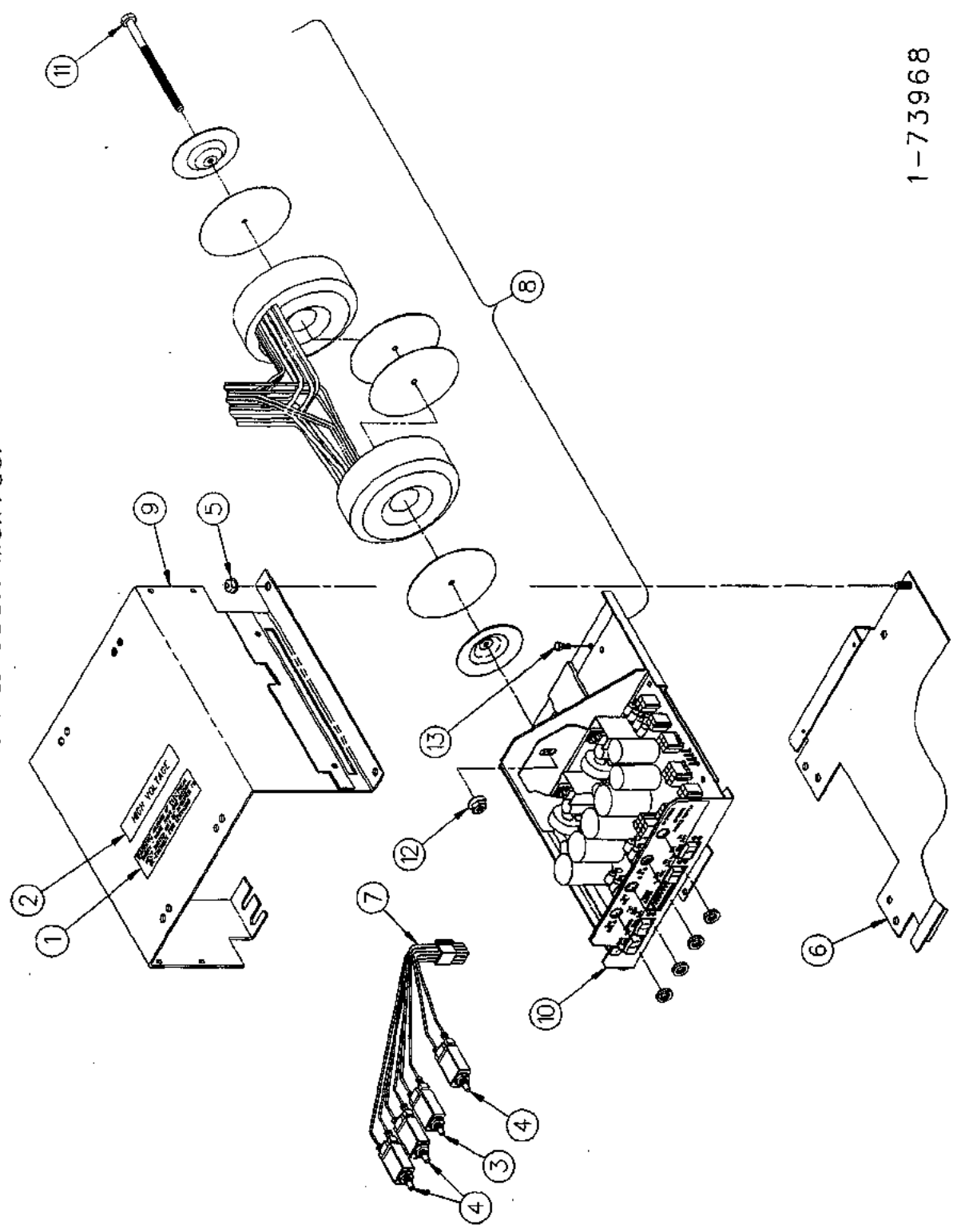

1-73968

1-73968

1 of 1

OPTIONS POWER SUPPLY ASSEMBLY (400A & 600A MaxVac)

ITEM NO.	PART NO.	DESCRIPTION
1	1-130404	Warning Label
2	1-227816	Label
3	6-228135	Circuit Breaker (2 Amp)
4	9-228135	Circuit Breaker (3 Amp)
5	2-228671	#10-24 Capped Washer Locknut
6	318813-1	Left Adapter Weld Assembly
7	319500-2	Circuit Breaker Harness Assembly
8	319582-1	Transformer Assembly
9	420226-2	Support Weld Assembly
10	421578-2	Options Power Supply Board Assembly
11	312-50361	1/4-20 x 4" Long Hex Head Cap Screw
12	01-54752	1/4-20 M-F Flange Whiz Lock Nut
13	23-55392	#8 x 3/8" Long Hex Washer Head Tapping Screw

For complete Circuit Breaker Harness Assembly order:
(Includes Item #3, 4 & 7) 319500-1

For complete Options Power Supply Assembly order: 421578-1

1-73968

