



Installation Guide For Tokheim Dispensers

Version 01
23 February, 2021

1414 Radcliffe St. Suite 120
Bristol, PA 19007
Phone: 215.785.6200
Fax: 215.785.0230

COPYRIGHT © 2021 ALLIED ELECTRONICS, INC.

Revision History

Version 01 February 23, 2021
Installation Guide for All Controller Types Established

Contents

1 General Information	4
1.1 Controller Type	4
1.2 Wiring.....	4
1.2.1 Field Wiring	4
1.2.2 Internal Wiring	4
2 Installation Information	6
2.1 Procedures	6
2.1.1 Hardware Installation- Aegis & NeXGen Prime	6
2.1.2 Hardware Installation- NeXGen.....	7
3 Startup	8
3.1 Audible feedback	8
3.2 Shutdown.....	8
3.3 Configuration Diagram.....	9
3.3.1 Allied Controller to Tokheim Dispensers.....	9
3.4 Communication Cable and RJ45 Pin Assignments.....	10
3.4.1 POS Communication	10
3.4.2 Tokheim Dispenser Communication.....	11
3.4.3 Tokheim DPT Communication.....	11
3.4.4 OPW OPT	12
3.4.5 Tank Gauge Communication	13
3.4.6 Car Wash Communication.....	16
3.4.7 Fuel Price Sign Communication	19
4 Programming	20
4.1 Tokheim Addressing	20
4.1.1 Tokheim Model #67 Interface boxes.....	20
4.1.2 Tokheim Dispensers and DPTs	21
4.1.3 Tokheim Blending Dispensers.....	22
4.1.4 Tokheim Debit Keypad Modules.....	24
4.2 Allied Controller Parameters Values and Options.....	25
4.3 Tokheim DPT Keypads	26
4.4 Peripheral Devices.....	37
4.4.1 Tank Gauge Systems	37
4.4.2 Car Wash Controllers	38
4.4.3 Fuel Price Signs	39

1 General Information

1.1 Controller Type

For the purpose of this document Allied Controller refers to NeXGen, NeXGen Prime, and Aegis. Refer to the controller specific User Manual for connection, firmware download, and configuration requirements.

1.2 Wiring

1.2.1 Field Wiring

All field wiring (that is, all wiring connected directly to dispensing devices) should be oil and gas resistant, as required by Paragraph 501-13 of the NEC, and should be sealed in accordance with Article 500 of the NEC.

1.2.2 Internal Wiring

1.2.2.1 Introduction

- a. The purpose of this section is to provide a list of installation practices that we feel are crucial to ensure error-free communications.
- b. All cabling must comply with Local, State, and Federal building codes.
- c. Data connections between the Forecourt Controller are to be made with CAT-5 Cable compliant with TIA/EIA-568-B or better.
- d. Proper cable installation techniques go a long way to preventing data loss.

1.2.2.2 Planning

- a. Pull cables in continuous runs.
- b. Do not splice any communications cables.
- c. Separate all cables from fluorescent lighting ballasts and neon sign transformers by at least 4 feet.
- d. Separate all cables from electrical supply conductors by at least 2 feet.
- e. Provide extra wire for service loops at the termination points but do not leave more than is required.

1.2.2.3 Execution

- a. Maintain the natural twist of the cable.
 - i. The cables have four pairs of twisted wires that can very easily lose their ability to reject electromagnetic interference when unraveled.
 - ii. Pay-out cable from spools so that the spool rotates.
- b. Avoid kinking and over-stressing the cable.
 - i. Kinks not only pick up interference, but can cause the jacket to chafe and internal conductors to break.
 - ii. Never exert more than 25 pounds of tension when pulling a communications cable.
- c. Provide a generous bend radius whenever the cable turns a corner.
 - i. Never bend the cable more than 90 degrees.
 - ii. Limit the bend to a 3 inch radius.
 - iii. Use a 1 pound coffee can as a guide.
- d. Support all cabling in both horizontal and vertical planes.
 - i. Unsupported horizontal cable runs, especially above drop ceilings, are problematic.
 - ii. In the event that cable trays are not available, the cabling can be secured with zip-ties, hook clips, J-hooks, or plastic coated staples provided they are spaced no greater than 2' apart.
 - iii. Do not use utility piping or drop ceiling grid-work to secure or support communications cables.
- e. Protect the cable from mechanical damage and install appropriate fire blocking whenever cables pass through floors or walls.
- f. Install carefully all zip-ties ensuring that they do not bite into the cable through excessive force.
- g. Label both ends of all cables.
- h. Use the proper punch down tool and ensure it is set properly.
 - i. Remove as little of the jacket as possible.
 - ii. Untwist the conductors as little as possible.

1.2.2.4 Testing

- a. Inspect thoroughly all cables for damage after they are pulled and before they are bundled or otherwise secured.
- b. Perform a continuity test of all pairs.

2 Installation Information

2.1 Procedures

2.1.1 Hardware Installation- Aegis & NeXGen Prime

For the purpose of this section the below images are samples from an Aegis Controller. Installation procedures are the same for Aegis, NeXGen, and NeXGen Prime.

- a. Attach the two mounting brackets to the Allied controller as shown in figure 2.
- b. Mount the Allied controller unit to the mounting area using the mounting holes as shown in figure 2. Underwriters Laboratories (UL) requires that the Allied Controller be mounted horizontally to the floor on a shelf perpendicular to the wall. The bottom of the unit should lay flat on the mounting surface. The mounting brackets secure the Allied Controller to the mounting surface.
- c. Route and connect all communication cables as labeled. Refer to “*Configuration Diagrams*” section (see figure 3).
- d. Apply AC power to unit by turning the power switch to the ON position (see figure 4).

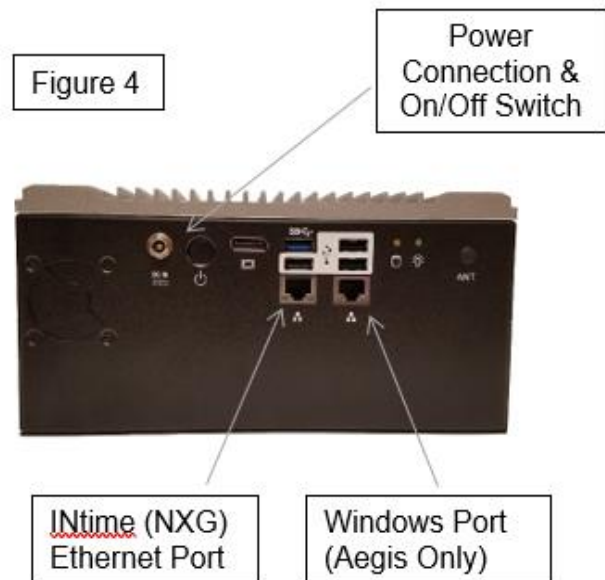
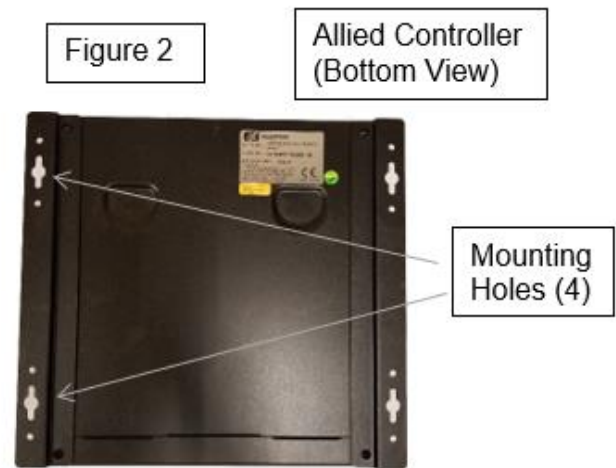

2.1.2 Hardware Installation- NeXGen

For the purpose of this section the below images are samples from a NeXGen Controller. Installation procedures are the same for Aegis, NeXGen, and NeXGen Prime.

- a. Attach the two mounting brackets to the Allied controller as shown in figure 2.
- b. Mount the Allied controller unit to the mounting area using the mounting holes as shown in figure 2. Underwriters Laboratories (UL) requires that the Allied Controller be mounted horizontally to the floor on a shelf perpendicular to the wall. The bottom of the unit should lay flat on the mounting surface. The mounting brackets secure the Allied Controller to the mounting surface.
- c. Route and connect all communication cables as labeled. Refer to “*Configuration Diagrams*” section (see figure 3).
- d. Apply AC power to unit by turning the power switch to the ON position (see figure 4).

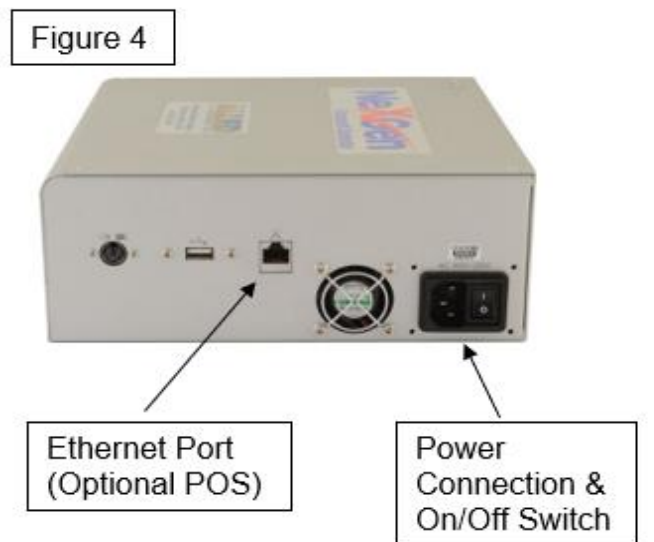
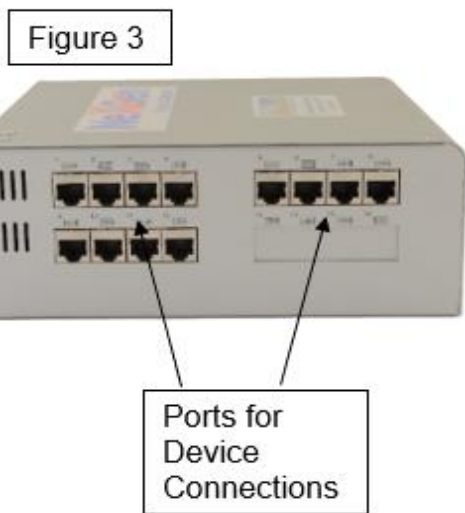
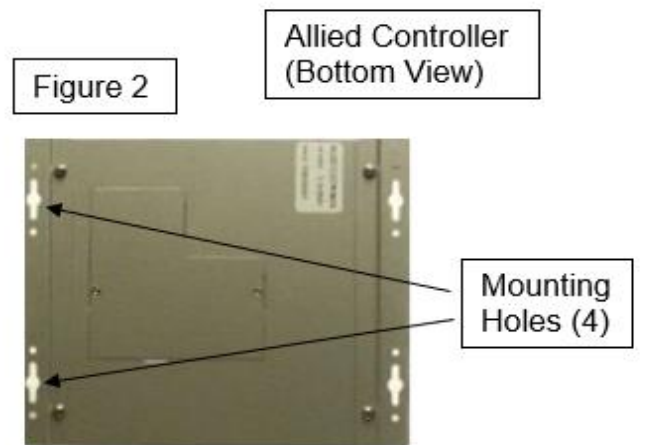
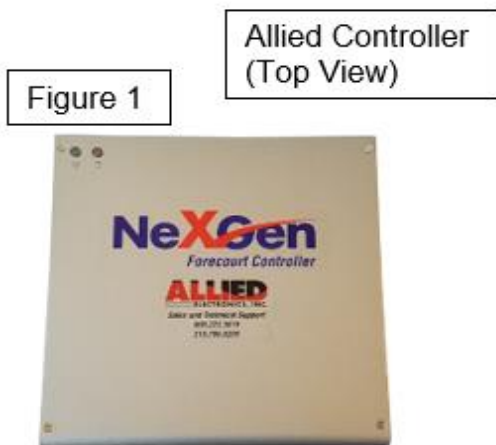

3 Startup

Take note that the term ANDI refers to the Allied Network Dispenser Interface – which is the protocol on which the embedded forecourt controller application is based.

After power is applied the INtime RTOS will start up and run the ANDI application. The Allied controller will beep indicating the events listed in section 3.1 were successful.

3.1 Audible feedback

- a. BIOS boot: one or several short beeps, shortly after power is applied.
- b. ANDI application startup: two beeps.
- c. ANDI has acquired an IP address: three beeps.

3.2 Shutdown

The entire system may be safely shut down by pressing the power key.

If a shutdown is initiated, it is critical to wait for the shutdown to complete before removing the power cord. Shutdown is complete when the power and disk LEDs go out and the fan stops spinning.

3.3 Configuration Diagram

3.3.1 Allied Controller to Tokheim Dispensers

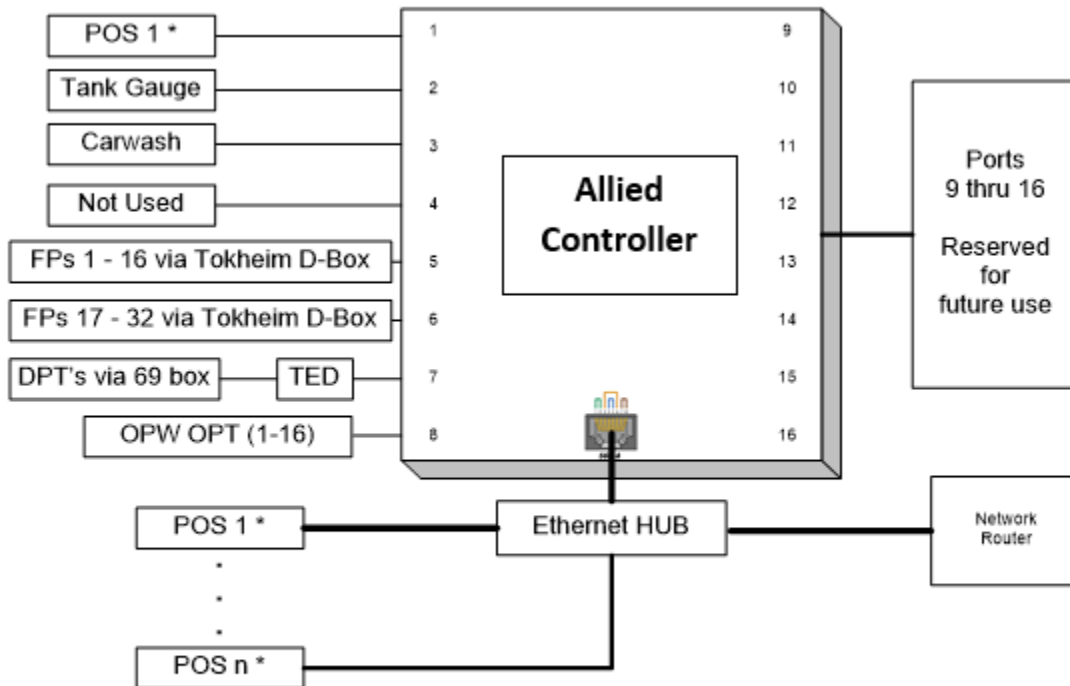

This figure describes the Allied Controller to Tokheim system installation.

* Note: denotes alternative POS connectivity options (RS232 vs. Ethernet)

Communication Ports

CH 1- POS.....	On board RS-232 port
CH 2- Tank Gauge (Optional).....	On board RS-232 port
CH 3- Carwash (Optional).....	On board RS-232 port
CH 4- Not Used or Reserved for Future Use	
CH 5- Dispenser.....	Tokheim 12V serial interface port
CH 6- Dispenser (Optional).....	Tokheim 12V serial interface port
CH 7- Card Readers/ DPTs & Debit Module.....	RS485 port 3-wire
CH 8- OPW OPT (Optional).....	RS-485 port 3-wire
CH 9- TBD (Optional)	Configurable Serial Port if present
CH 10- TBD (Optional)	Configurable Serial Port if present
CH 11- TBD (Optional)	Configurable Serial Port if present
CH 12- TBD (Optional)	Configurable Serial Port if present
CH 13- TBD (Optional)	Configurable Serial Port if present
CH 14- TBD (Optional)	Configurable Serial Port if present
CH 15- TBD (Optional)	Configurable Serial Port if present
CH 16- TBD (Optional)	Configurable Serial Port if present
ETHERNET	Network and POS

Note: Contact Technical Support for available options

3.4 Communication Cable and RJ45 Pin Assignments

3.4.1 POS Communication

The Allied Controller supports up to 8 POSs. The POS is a PC based computer which runs the Point-Of-Sale software. The serial port on the POS can be either a DB-25 or a DB-9 connector.

Allied Controller (CH1) RJ45 adapter to POS (Serial Port, DB25) (Part #N9325-ADP)

Allied Controller RJ45 Pins	CAT 5 Cable (T568B Spec.)	RJ45 Modular Jack Pins	POS DB25 Female Pins
DSR 2	----- Orange -----	2 (Org)	20 DTR
RXD 3	----- Wht/Grn -----	3 (Blk)	2 TXD
RTS 4	----- Blue -----	4 (Red)	5 CTS
TXD 5	----- Wht/Blu -----	5 (Grn)	3 RXD
CTS 6	----- Green -----	6 (Yel)	4 RTS
DTR 7	----- Wht/Brn -----	7 (Brn)	6 DSR
GND 8	----- Brown -----	8 (Wht)	7 GND

Allied Controller (CH1) RJ45 adapter to POS (Serial Port, DB9) (Part #N9359-ADP)

Allied Controller RJ45 Pins	CAT 5 Cable (T568B Spec.)	RJ45 Modular Jack Pins	POS DB9 Female Pins
DSR 2	----- Orange -----	2 (Org)	4 DTR
RXD 3	----- Wht/Grn -----	3 (Blk)	3 TXD
RTS 4	----- Blue -----	4 (Red)	8 CTS
TXD 5	----- Wht/Blu -----	5 (Grn)	2 RXD
CTS 6	----- Green -----	6 (Yel)	7 RTS
DTR 7	----- Wht/Brn -----	7 (Brn)	6 DSR
GND 8	----- Brown -----	8 (Wht)	5 GND

3.4.2 Tokheim Dispenser Communication

Up to two Tokheim 98 or 67 boxes may be connected on each dispenser communications Channel. Each box must have a 6-wire custom cable which terminates in a 16-position male CPC (Circular Plastic Connector).

This cable connects to CH5 or CH6 and supports up to 16 fueling positions.

Allied Controller (CH5 or CH6) RJ45 adapter to Tokheim Model 67 or 98 box (Part #N9303-ADP)

Allied Controller RJ45 Pins		CAT 5 Cable (T568B Spec.)		RJ45 Adapter Pins		Tokheim Circular Connector Pins
Signal GND 1	-----	Wht/Org	-----	1 (Blu)		6 Signal GND
Emergency Stop 3	-----	Wht/Grn	-----	3 (Blk)		10 Emergency Stop
RXD 4	-----	Blue	-----	4 (Red)		3 RXD
Drain 5	-----	Wht/Blu	-----	5 (Grn)		16 Drain
TXD 7	-----	Wht/Brn	-----	7 (Brn)		2 TXD
Emergency Stop 8	-----	Brown	-----	8 (Wht)		11 Emergency Stop

3.4.3 Tokheim DPT Communication

Allied Controller (CH7 or CH8) RJ45 adapter to Tokheim Model 69 box (Part #N9301-ADP)

Allied Controller RJ45 Pins		CAT 5 Cable (T568B Spec.)		RJ45 Adapter Pins		Tokheim 69 box J1 Connector Screws
Signal GND 3	-----	Wht/Grn	-----	3 (Blk)		3 Signal GND
RS485 (-) 4	-----	Blue	-----	4 (Red)		1 RS485 (-)
Drain 5	-----	Wht/Blu	-----	5 (Grn)		4 Drain
RS485 (+) 8	-----	Brown	-----	8 (Wht)		2 RS485 (+)

3.4.4 OPW OPT

The Allied Controller uses Channel 8 to interface to the OPW OPT's. Up to 16 OPT's may be connected. Software Version 18.01A, or newer, must be installed in the OPT and it must be configured as follows:

Baud Rate: 9600, Data Bits: 8, Parity: None, Stop Bits: 1

Allied Controller (CH8) RJ45 adapter to the OPW OPT Junction box *(Part #N9409-ADP)*

Allied Controller RJ45 Pins		CAT 5 Cable (T568B Spec.)		RJ45 Modular Jack Pins	OPW OPT "J" box Terminal
RS485 + 1	-----	Wht/Org	-----	1 (Blue)	1 RS485 +
RS485 - 2	-----	Orange	-----	2 (Orange)	2 RS485 -

3.4.5 Tank Gauge Communication

The Allied Controller uses Channel 2 to interface to a Veeder-Root or equivalent tank gauge system. Configure the tank gauge communication parameters as follows:

Baud Rate: 9600 Parity: Odd Stop Bits: 1 Data Bits: 7

3.4.5.1 Veeder Root TLS 250/350

On a TLS-250, the communication parameters are set using a rotary switch and DIP switches, (please refer to the TLS 250 manual).

On a TLS-350, the communication parameters are programmed via the TLS keyboard (please refer to the TLS 350/350R manual).

On a TLS-450, the communication parameters are programmed via the touch-screen display (please refer to the TLS 450 manual).

Allied Controller (CH 2) RJ45 adapter to the VR TLS 250/350 (Part #N9338-ADP)

Allied Controller RJ45 Pins	CAT 5 Cable (T568B Spec.)	RJ45 Adapter Pins	TLS DB25 Male Pins
RXD 3	----- Wht/Grn -----	3 (Blk)	2 TXD
TXD 5	----- Wht/Blu -----	5 (Grn)	3 RXD
GND 8	----- Brown -----	8 (Wht)	7 GND

3.4.5.2 Veeder Root TLS 450

Allied Controller (CH2) RJ45 adapter to the VR TLS 450 (Part #N9445-ADP)

Allied Controller RJ45 Pins	CAT 5 Cable (T568B Spec.)	RJ45 Modular Jack Pins	TLS DB9 Male Pins
DSR 2	----- Orange -----	2 (Org)	4 DTR
RXD 3	----- Wht/Grn -----	3 (Blk)	3 TXD
RTS 4	----- Blue -----	4 (Red)	8 CTS
TXD 5	----- Wht/Blu -----	5 (Grn)	2 RXD
CTS 6	----- Green -----	6 (Yel)	7 RTS
DTR 7	----- Wht/Brn -----	7 (Brn)	6 DSR
GND 8	----- Brown -----	8 (Wht)	5 GND

3.4.5.3 Red Jacket ST

Allied Controller (CH 2) RJ45 adapter to the Red Jacket “ST”

Allied Controller RJ45 Pins	CAT 5 Cable (T568B Spec.)	RJ45 Adapter Pins	Red Jacket DB9 Female Pins
RXD 3	----- Wht/Grn -----	3 (Blk)	3 TXD
TXD 5	----- Wht/Blu -----	5 (Grn)	2 RXD
GND 8	----- Brown -----	8 (Wht)	5 GND

3.4.5.4 Omntec

Allied Controller (CH 2) RJ45 adapter to the OMNTEC OEL 8000 II

Allied Controller RJ45 Pins	CAT 5 Cable (T568B Spec.)	RJ45 Adapter Pins	OMNTEC DB9 Female Pins
RXD 3	----- Wht/Grn -----	3 (Blk)	2 TXD
TXD 5	----- Wht/Blu -----	5 (Grn)	3 RXD
GND 8	----- Brown -----	8 (Wht)	5 GND

3.4.5.5 OPW EECO

Allied Controller (CH 2) RJ45 adapter to the OPW EECO #1500, 2000, 3000 (Part #N9396-ADP)

Allied Controller RJ45 Pins	CAT 5 Cable (T568B Spec.)	RJ45 Adapter Pins	EECO DB9 Male Pins
RXD 3	----- Wht/Grn -----	3 (Blk)	3 TXD
RTS 4	----- Blue -----	4 (Red)	8 CTS
TXD 5	----- Wht/Blu -----	5 (Grn)	2 RXD
GND 8	----- Brown -----	8 (Wht)	5 GND

3.4.5.6 *Incon Tank Sentinel*

Allied Controller (CH 2) RJ45 adapter to the Incon Tank Sentinel
(Part #N9389-ADP)

Allied Controller RJ45 Pins	CAT 5 Cable (T568B Spec.)	RJ45 Adapter Pins	Incon/Comm 1 DB9 Male Pins
RXD 3	----- Wht/Grn -----	3 (Blk)	2 TXD
TXD 5	----- Wht/Blu -----	5 (Grn)	3 RXD
GND 8	----- Brown -----	8 (Wht)	5 GND

1.1.1.1 *TS-550EVO*

Allied Controller (CH2) RJ45 adapter to the TS-550EVO
(Part #N9449-ADP)

Allied Controller RJ45 Pins	CAT 5 Cable (T568B Spec.)	RJ45 Modular Jack Pins	TS DB9 Female Pins
RXD 3	----- Wht/Grn -----	3 (Blk)	2 TXD
RTS 4	----- Blue -----	4 (Red)	8 CTS
TXD 5	----- Wht/Blu -----	5 (Grn)	3 RXD
CTS 6	----- Green -----	6 (Yel)	7 RTS
GND 8	----- Brown -----	8 (Wht)	5 GND
DSR 2	----- Orange -----	2 (Org)	Tie to Brown
DTR 7	----- Wht/Brn -----	7 (Brn)	Tie to Orange

3.4.6 Car Wash Communication

The Allied Controller uses channel 3 to interface to the car wash controller. Six different car wash controller pinouts are listed in the section below:

- Ryko Code-A-Wash III
- Ryko Code-A-Wash IV (S/N less than 166600)
- Ryko Code-A-Wash IV (S/N 166600 or greater)
- Unitec POS 4000
- Unitec Portal Ti
- Unitec Enterlink
- Unitec Smart terminal
- Kesseltronics Standard
- Kesseltronics Advanced dual bay w/DB9 connection
- Kesseltronics Advanced dual bay w/RJ45 connection

3.4.6.1 Ryko III and Kesseltronics Standard

Allied Controller (CH 3) RJ45 adapter to the Ryko Code A Wash III and Kesseltronics Standard

(Part #N9348-ADP)

Allied Controller RJ45 Pins	CAT 5 Cable (T568B Spec.)	RJ45 Adapter Pins	Car Wash DB9 Male Pins
RXD 3	----- Wht/Grn -----	3 (Blk)	9 TXD
TXD 5	----- Wht/Blu -----	5 (Grn)	8 RXD
GND 8	----- Brown -----	8 (Wht)	7 GND
			1 CTS
			4 DCD

3.4.6.2 Ryko IV (S/N less than 166600), Unitec POS 4000, Portal Ti, Exacta & DRB

Allied Controller RJ45 adapter to the Ryko Code A Wash IV, Unitec POS 4000, Portal Ti, Exacta & DRB

(Part #N9344-ADP)

Allied Controller RJ45 Pins	CAT 5 Cable (T568B Spec.)	RJ45 Adapter Pins	Car Wash DB9 Female Pins
RXD 3	----- Wht/Grn -----	3 (Blk)	3 TXD
RTS 4	----- Blue -----	4 (Red)	8 CTS
TXD 5	----- Wht/Blu -----	5 (Grn)	2 RXD
DTR 7	----- Wht/Brn -----	7 (Brn)	6 DSR
GND 8	----- Brown -----	8 (Wht)	5 GND

3.4.6.3 *Unitec Enterlink, Smart terminal and Ryko IV (S/N 166600 or greater)*

Allied Controller (CH 3) RJ45 adapter to the Unitec/Enterlink
(Part #N9352-ADP)

Allied Controller RJ45 Pins	CAT 5 Cable (T568B Spec.)	RJ45 Adapter Pins	Enterlink DB9 Female Pins
RXD 3	----- Wht/Grn -----	3 (Blk)	3 TXD
TXD 5	----- Wht/Blu -----	5 (Grn)	2 RXD
GND 8	----- Brown -----	8 (Wht)	5 GND

3.4.6.4 *PDQ*

Allied Controller (CH 3) RJ45 adapter to the PDQ
(Part #N9352-ADP)

Allied Controller RJ45 Pins	CAT 5 Cable (T568B Spec.)	RJ45 Adapter Pins	PDQ DB9 Female Pins
RXD 3	----- Wht/Grn -----	3 (Blk)	3 TXD
TXD 5	----- Wht/Blu -----	5 (Grn)	2 RXD
GND 8	----- Brown -----	8 (Wht)	5 GND

3.4.6.5 Kesseltronics Advanced dual bay via the MUX PAP isolator box

**Allied Controller (CH 3) RJ45 adapter to the Kesseltronics
 “Advanced Dual bay” via MUX PAP isolator box /DB9
 (Part #N9352-ADP)**

Allied Controller RJ45 Pins	CAT 5 Cable (T568B Spec.)	RJ45 Adapter Pins	Kesseltronics ADB DB9 Female Pins
RXD 3	----- Wht/Grn -----	3 (Blk)	3 TXD
TXD 5	----- Wht/Blu -----	5 (Grn)	2 RXD
GND 8	----- Brown -----	8 (Wht)	5 GND

**Allied Controller (CH 3) RJ45 adapter to the Kesseltronics
 “Advanced Dual bay” via MUX PAP isolator box /RJ45**

Allied Controller RJ45 Pins	CAT 5 Cable (T568B Spec.)	Kesseltronics ADB RJ45 Pins
RXD 3	----- Wht/Grn -----	3 TXD
TXD 5	----- Wht/Blu -----	2 RXD
GND 8	----- Brown -----	4 GND

3.4.7 Fuel Price Sign Communication

The Allied Controller uses an RS232 channel to interface to the Fuel Price Sign.

3.4.7.1 Daktronics Fuel Price Sign (Minimum version required is 5.8)

Allied Controller (CH-RS232) RJ45 adapter to the Daktronics Fuel Price Sign
(Part #N9443-ADP)

Allied Controller RJ45 Pins	CAT 5 Cable (T568B Spec.)	RJ45 Modular Jack Pins	Daktronics DB9 Female Pins
TXD 5	----- Wht/Blu	----- 5 (Grn)	2 RXD
RXD 3	----- Wht/Grn	----- 3 (Blk)	3 TXD
GND 8	----- Brown	----- 8 (Wht)	5 GND
DSR 2	----- Orange	----- 2 (Org)]	
DTR 7	----- Wht/Brn	----- 7 (Brn)]	
RTS 4	----- Blue	----- 4 (Red)]	
CTS 6	----- Green	----- 6 (Yel)]	

3.4.7.2 Future Media Displays Fuel Price Sign

Allied Controller (CH-RS232) RJ45 adapter to the FMD Fuel Price Sign
(Part #N9411-ADP)

Allied Controller RJ45 Pins	CAT 5 Cable (T568B Spec.)	RJ45 Adapter Pins	FMD DB9 Male Pins
RXD 3	----- Wht/Grn	----- 3 (Blk)	2 TXD
TXD 5	----- Wht/Blu	----- 5 (Grn)	3 RXD
GND 8	----- Brown	----- 8 (Wht)	5 GND

3.4.7.3 PWM Fuel Price Sign

Allied Controller (CH-RS232) to the PWM Fuel Price Sign

Allied Controller RJ45 Pins	CAT 5 Cable (T568B Spec.)	PWM CAT 5 Cable
DSR 2	----- Orange] Loop to DTR
DTR 7	----- Wht/Brn	
RXD 3	----- Wht/Grn] Loop to DSR
RTS 4	----- Blue	
TXD 5	----- Wht/Blu	5 TXD
CTS 6	----- Green	2 CTS
GND 8	----- Brown	4 RXD
		3 RTS
		1 GND

3.4.7.4 Skyline Fuel Price Sign

Allied Controller (CH-RS232) RJ45 adapter to the Skyline Fuel Price Sign
(Part #N9446-ADP)

Allied Controller RJ45 Pins	CAT 5 Cable (T568B Spec.)	RJ45 Modular Jack Pins	POS DB9 Male Pins
DSR 2	Orange	2 (Org)	6 DTR
RXD 3	Wht/Grn	3 (Blk)	2 TXD
RTS 4	Blue	4 (Red)	7 CTS
TXD 5	Wht/Blu	5 (Grn)	3 RXD
CTS 6	Green	6 (Yel)	8 RTS
DTR 7	Wht/Brn	7 (Brn)	4 DSR
GND 8	Brown	8 (Wht)	5 GND

4 Programming

4.1 Tokheim Addressing

4.1.1 Tokheim Model #67 Interface boxes

Tokheim manufactures two model #67 interface boxes, model #67A and #67B. The 67B interface box must be “downgraded” to be a #67A in order for it to communicate to an Allied Controller. The 67B interface box will not operate with any Allied interface systems.

The downgrade consists of the following changes:

1. Disconnect *J6* and *J8* from the interface motherboard (Part# 316386-1).
2. Disconnect *J3* from the interface power supply board (Part# 421483-1). This board is only in the 67B interface box.
3. *J3*, *J6* and *J8* make up a complete cable assembly. Discard the entire assembly.
4. Disconnect *J4* from the power supply board and connect it into *J6* on the motherboard.

Note: Once this “downgrade” is completed, the 67 box will communicate with the Allied interface.

4.1.2 Tokheim Dispensers and DPTs

Two Channels (5 and 6) have been designated to communicate with the Tokheim dispensers. Each Channel can accommodate up to 16 fueling positions. The address of the first fueling position on Channel 5 will be set to address “1”, the second to address “2” etc. If Channel 6 is used, the address of the first fueling position connected on this Channel will also be set to address “1”, the second to address “2” etc. See example.

Two Channel (7) has been designated to communicate with the Tokheim DPTs. The DPT device address must be the same as the fueling position number.

The Allied Controller uses channel 8 to communicate with the OPW OPT. Up to 16 OPT’s can be supported and software Version 18.01A, or newer, must be installed. The OPT uses decimal address 32 – 47.

Fueling Positions			DPT		OPT	
Fueling Position	Address	Allied Controller Channel	Tokheim/Address	Allied Controller Channel	OPT Address	Allied Controller Channel
1	1	CH-5	1	CH-7	32	CH-8
2	2	CH-5	2	CH-7	33	CH-8
3	3	CH-5	3	CH-7	34	CH-8
4	4	CH-5	4	CH-7	35	CH-8
5	5	CH-5	5	CH-7	36	CH-8
6	6	CH-5	6	CH-7	37	CH-8
7	7	CH-5	7	CH-7	38	CH-8
8	8	CH-5	8	CH-7	39	CH-8
9	9	CH-5	9	CH-7	40	CH-8
10	10	CH-5	10	CH-7	41	CH-8
11	11	CH-5	11	CH-7	42	CH-8
12	12	CH-5	12	CH-7	43	CH-8
13	13	CH-5	13	CH-7	44	CH-8
14	14	CH-5	14	CH-7	45	CH-8
15	15	CH-5	15	CH-7	46	CH-8
16	16	CH-5	16	CH-7	47	CH-8
17	1	CH-6	17	CH-7		
18	2	CH-6	18	CH-7		
19	3	CH-6	19	CH-7		
20	4	CH-6	20	CH-7		
21	5	CH-6	21	CH-7		
22	6	CH-6	22	CH-7		
23	7	CH-6	23	CH-7		
24	8	CH-6	24	CH-7		
25	9	CH-6	25	CH-7		
26	10	CH-6	26	CH-7		
27	11	CH-6	27	CH-7		
28	12	CH-6	28	CH-7		
29	13	CH-6	29	CH-7		
30	14	CH-6	30	CH-7		
31	15	CH-6	31	CH-7		
32	16	CH-6	32	CH-7		

4.1.3 Tokheim Blending Dispensers

Variable Blenders

The Allied Controller interfaces to the following types of Tokheim variable blenders:

Premier Multi hose, multi product blender
Single hose, multi product blender
Single hose, multi product + diesel blender

Fixed Blenders

The Allied Controller interfaces to the following types of Tokheim fixed blenders:

- TCSA blender
- Premier Multi hose, multi product blender
- Premier single hose, muti product blender
- One of the above with diesel

Dispenser Programming

Mode 26 of the dispenser programming must be configured correctly for the blend ratios. The programming screen for the dispenser is shown below, for variable blenders.

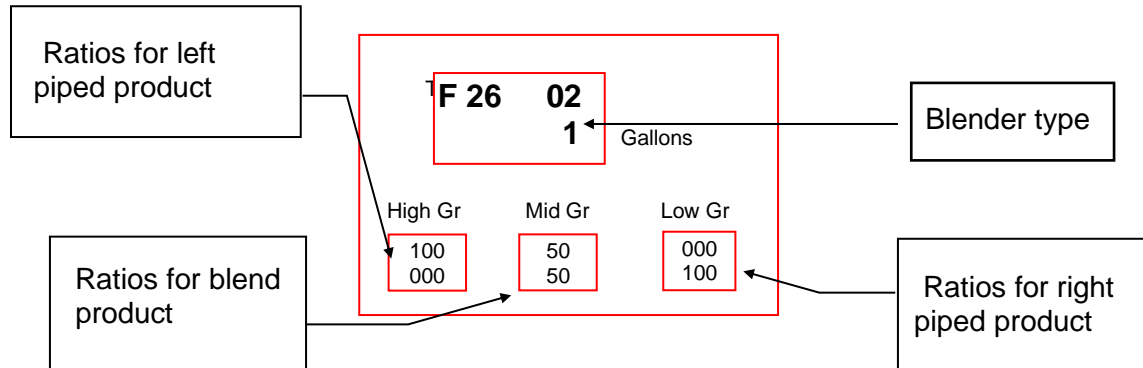

1) In mode 26 on the right side of the gallon display window a **0 ,1 or 2** may be showing in the gallon window. This option sets the **Blender type**.

0 = Blender used without ratio verification*

1 = Blender used with ratio verification*

2 = Blender used with a controller that does not support blenders

* **ratio verification** - The POS ratios must match the dispenser ratios. If the ratios do not match, an error message, “**Blend Ratio Error**”, will be displayed on the dispenser card reader, if present, when the customer attempts to reset and begin fueling the blended product.

2) Set the blender ratios. Each product has two ratios which are displayed in the PPG windows:

Top line = ratio of the left piped product

Bottom line = ratio of the right piped product

As shown in the figure above, the left piped product has 100 % of the high grade and 0 % of the low grade. The right piped product has 0 % of the high grade and 100 % of the low grade.

The blend product allows the left (top) grade to be set, and automatically adjusts the bottom grade ratio so the sum of the ratios equals 100. The **Blended Fuels Ratios** settings in the POS must match the dispenser setting.

Product to Position Mapping

Tokheim dispensers do not require special product to position mapping in the POS **Fueling Point Configuration** menu. The products are set to positions 1 through 3 for a 3 product dispenser, positions 1 through 4 for a 4 product dispenser and positions 1 through 5 for a 5 product dispenser. The table below lists the proper product to position assignment for a 4 product dispenser.

The **blender type** setting for each fueling point must be set properly to one of the values listed below.

2 = Fixed blender

3 = Variable blender or Variable + 1 with the non blended products set as “non” in Mode 26

4 = Variable blender with the non blended product set as a ratio

5 = Variable blender + 1 with the non blended product set as a ratio

Position	Product
1	Low grade
2	Blended product
3	High grade
4	Diesel
5	Not assigned
6	Not assigned
7	Not assigned
8	Not assigned

** The low grade and the high grade products may be switched depending on the position of the dispenser and the installation of the product lines.*

4.1.4 Tokheim Debit Keypad Modules

The Tokheim Debit Keypad Modules must be ordered from Tokheim for a specific Network application. They should be configured by Tokheim for the location. There are no switches or jumpers to be set.

4.2 Allied Controller Parameters Values and Options

The Allied Controller configuration is provided and sent to the controller by the POS. The POS has to download all required parameters to the Allied Controller. The controller will start polling the dispensers, CRINDs and other peripheral devices only after the POS has downloaded all necessary station configuration data.

Examples Of Parameters Downloaded from POS:

- DPT Configuration
- Fuel Information
- Product Information
- Car Wash Information
- Cash / Credit Limits
- Mode of Service
- Default Price Level
- Sale Stacking
- Number of fueling points
- Network site specific parameters

4.3 Tokheim DPT Keypads

Please note that the keypads listed below are predefined within the controller. All other keypad types can be configured via the POS to the Allied Controller interface using the “DPT Configure Keyboard” command.

Type 1

1	2	3		Pay Outside Credit	S t a r t
4	5	6	Pay Inside Cash	Pay Inside Credit	
7	8	9	No	Yes	
Clear	0	Enter	Help	Cancel	

Type 2

Pay Inside		Pay Here	
Receipt No		Receipt Yes	
1	2	3	C l e a r
4	5	6	
7	8	9	E n t e r
Help	0	Cancel	

Type 3

1	2	3		Pay Outside	S t a r t
4	5	6		Pay Inside	
7	8	9	No	Yes	
Clear	0	Enter	Help	Cancel	

Type 4

1	2	3		Pay Outside	
4	5	6		Pay Inside	
7	8	9	No	Yes	
Clear	0	Enter	Help	Cancel	

Type 5

1	2	3		Pay Outside Credit	
4	5	6	Pay Inside Cash	Pay Inside Credit	
7	8	9	No	Yes	
Clear	0	Enter	Help	Cancel	

Type 6

1	2	3	Pay Outside Debit	Pay Outside Credit	
4	5	6	Pay Inside Cash	Pay Inside Credit	
7	8	9	No	Yes	S t a r t
Clear	0	Enter	Help	Cancel	

Type 7

1	2	3	Outside Debit	Outside Credit	XXX
4	5	6	XXX	Pay Inside	XXX
7	8	9	No	Yes	Start
Clear	0	Enter	Help	Cancel	

Type 8

1	2	3	Pay Outside		
4	5	6		Pay Inside	
7	8	9	Yes	Help	
Clear	0	Enter	No	Cancel	

		Start		
--	--	--------------	--	--

Type 9

1	2	3		Pay Inside	
4	5	6		Pay Here	
7	8	9	No	Yes	S t a r t
Clear	0	Enter	Help	Cancel	

Type A

1	2	3		Pay Outside	
4	5	6		Pay Inside	
7	8	9	No	Yes	S t a r t
Clear	0	Enter	Help	Cancel	

Type B

1	2	3	Pay Outside Debit	Pay Outside Credit	
4	5	6		Pay Inside	
7	8	9	No	Yes	S t a r t
Clear	0	Enter	Help	Cancel	

Type C

1	2	3		Pay Outside Credit	
4	5	6	Pay Outside Cash	Pay Inside	
7	8	9	No	Yes	S t a r t
Clear	0	Enter	Help	Cancel	

Type D

1	2	3	Pay Outside Debit	Pay Outside Credit	
4	5	6	Pay Outside Cash	Pay Inside	
7	8	9	No	Yes	S t a r t
Clear	0	Enter	Help	Cancel	

Type E

1	2	3	Yes	
4	5	6	No	
7	8	9	Help	S t a r t
Clear	0	Enter	Cancel	

Type G

1	2	3	Outside Credit		
4	5	6	Outside Debit		
7	8	9	Yes	No	
Clear Cancel	0	Enter	Help		

Type H (Premier C – Insight)

	1	2	3	HELP	Y E S
	4	5	6	Cancel	
	7	8	9		N O
	Clear	0	ENTER		

Type I

1	2	3	Outside Debit	Outside Credit	
4	5	6		Pay Inside	
7	8	9	Yes	Help	
Clear	0	Enter	NO	Cancel	

Type J (Canada)

1	2	3	YES		
4	5	6	NO		
7	8	9	Checking		H E L P
Clear	0	OK	Savings	Cancel	

Type K (Premier C – Insight)

	1	2	3	HELP	Y E S
	4	5	6	Cancel	
	7	8	9		N O
	Clear	0	ENTER	DEBIT	

Type L

1	2	3	Pay Inside		
4	5	6	YES		
7	8	9	NO		
Clear	0	Enter	Help	Cancel	

4.4 Peripheral Devices

4.4.1 Tank Gauge Systems

The Allied Controller uses Channel 2 to interface to either the Veeder-Root tank gauge system or compatible system. The controller is connected to the serial board on a device and it may be connected to the DIM board on a TLS 350R.

When the controller is connected to the DIM board on a TLS 350R, it will send real-time fuel transaction data (i.e. sale started, sale complete, volume dispensed, meter reading etc.). This is accomplished by implementing the Veeder-Root Dispenser Interface Protocol (a proprietary interface defined by Veeder-Root for the TLS 350R). This will allow the TLS to utilize the AccuChart Automatic Tank Calibration feature for underground storage tank reconciliation.

Configure the TLS-250/350/350R or the Red Jacket communication parameters as follows:

Baud Rate - 9600, Parity - Odd, Stop Bits - 1, Data Bits - 7

Notes:

On a TLS-250, the communication parameters are set using a rotary switch and some DIP switches, (please refer to the TLS 250 manual).

On a TLS-350/350R, the communication parameters are programmed via the TLS keyboard (please refer to the TLS 350/350R manual).

No additional controller configuration is needed. The Allied Controller will automatically check if it is connected to a DIM card. Otherwise, the controller will not send any Dispenser Interface commands to the TLS. Communicating with other devices requires POS programming.

4.4.2 Car Wash Controllers

The following requirements must be met in order for the Car Wash controllers to communicate to the Allied Controller.

Car Wash controller	Software Version
Ryko Code A Wash III	"8B" or newer
Ryko Code A Wash IV	"V" (1)
Unitec POS 4000	"6.50" or newer (2)
Unitec Portal Ti	Any version
Unitec/Enterlink	Any version
Unitec Smart terminal	
Kesseltronics	Any version
PDQ	Any version

Notes:

1. The Ryko Code-A-Wash IV should communicate to the Allied Controller using any version of software. However, Ryko recommends that the controller be upgraded to the latest version.
2. The Unitec software must be able to support External POS 1, 2 or 3. This information may be found either on the PROM label which is located inside the controller, or via the configuration report printed from the controller. There will be a line on the report indicating the "External POS" type.
 - a. The Unitec controller must be programmed to use the Ryko protocol. See section 6.2.10 in the External POS Menu of the Unitec manual. Set POS offset to "0", Down. Set External POS type to "2". Set baud rate to 9600.
 - b. If the Unitec hardware version is 6.1, a (SA1606) 9 pin adapter (which can be ordered from Unitec, if required) must be used to connect the serial port to the communication cable. If the hardware version is 6.2 or higher, the communication cable must be connected directly to the 9 pin serial port.
 - c. To distinguish the difference between 6.1 type hardware and 6.2 type hardware, look at the label attached to the base of the unit. If the Model field has "POS4000" then it unit is equipped with 6.1 hardware. If it has "POS4000/2" (or /3 etc.) then it is equipped with 6.2 or higher hardware. The 6.2 and higher cable pinouts are standard for a 9-pin DTE serial port, which is not the case for 6.1 units.
3. The Ryko Code A Wash II will not work with the Allied Controller. It can be upgraded to a Code A Wash III.

4.4.3 Fuel Price Signs

The Allied Controller supports the Future Media Display (FMD) protocol. The use of the FMD electronic price sign is configurable and can be mapped to an available serial RS232 port via the Allied Diagnostic (ANDI_DGS) utility.

The following signs communicate with the Allied Controller via the use of the ANDI protocol message set. These devices physically connect to an available POS RS232 for communications.

- PWM
- Daktronics
- Skyline
- Sunshine

The controllers noted above may have specific software version requirements for the support of the ANDI protocol interface. Please contact the respective manufacturer for specific details.

Other sign integrations are currently under development. Please contact Allied Electronics, Inc. for up to date details regarding other possible signs that have integrated to the controller.