

ALLIED ELECTRONICS, INC
STATION SITE CONTROLLER (SSC)

Installation and Start Up Guide

Shell / ANDI
to Tokheim



ALLIED ELECTRONICS, INC
2210 FARRAGUT AVENUE
BRISTOL, PA 19007-0624
PHONE: 215.785.6200
FAX: 215.785.0230

COPYRIGHT © 2003 BY ALLIED ELECTRONICS, INC.

Table of Contents

- 1. General Information..... 1-1**
 - 1.1. Installation Environment..... 1-1
 - 1.2. Warranty..... 1-1
 - 1.3. FCC Warning 1-2
 - 1.4. Overview 1-3
 - 1.5. Installation Information 1-4
 - 1.5.1. Procedures..... 1-4
 - 1.6. Configuration Diagram 1-5
 - 1.6.1. SSC to Tokheim 1-5
 - 1.7. Communication Cable Pin Assignments 1-6
 - 1.7.1. POS Communication Cables..... 1-6
 - 1.7.2. Tokheim Pump Control (Single) 1-7
 - 1.7.3. Tokheim Pump Control (Dual)..... 1-8
 - 1.7.4. Tokheim DPT 1-9
 - 1.7.5. TLS-250/350/350R or Equivalent Cable..... 1-10
 - 1.7.6. Shell VSAT Cable..... 1-11
- 2. Programming..... 2-1**
 - 2.1.1. Tokheim Addressing..... 2-1
 - 2.1.1.1. Tokheim Model #67 Interface boxes 2-1
 - 2.1.1.2. Tokheim Dispensers and DPTs..... 2-2
 - 2.1.1.3. Tokheim Blending Dispensers..... 2-3
 - 2.1.1.4. Tokheim Debit..... 2-5
 - 2.2. SSC Parameters Values and Options 2-6
 - 2.3. Keypads 2-7
 - 2.4. Peripheral Devices 2-9
 - 2.4.1. Tank Gauge System..... 2-9

1. General Information

1.1. Installation Environment

1. The Allied Electronics Station Site Controller (SSC) operates on 115 Vac @60hz,36 watts. The SSC is supplied with approximately 8ft. of 115 Vac power cord, and should be connected to an approved isolated ground receptacle on its own dedicated circuit. The SSC must be installed in a temperature controlled environment (between 32⁰ F and 100⁰ F).
2. Allied Electronics recommends that the SSC be installed with a UL Listed Power Conditioner to protect against power surges, low voltage (brown outs), and lightning.
3. The SSC must be installed in accordance with the National Electrical Code (NFPA 70), the Automotive and Marine Service Station Code (NFPA 30A), and all state and local electrical codes.
4. The SSC must be installed indoors, above the Class 1, Division 2 Hazardous location.
5. All field wiring (that is, all wiring connected directly to dispensing devices) should be oil and gas resistant, as required by Paragraph 501-13 of the NEC, and should be sealed in accordance with Article 500 of the NEC.
6. For use with peripheral devices which are UL Listed, have an EIA RS232C (or RS422A) communication protocol, and are installed over a hazardous location.

1.2. Warranty

The SSC has a one year parts warranty only, from date of installation, which can either be phoned in or submitted using the warranty/registration card enclosed in every SSC. If the start up information is not registered with our office within thirty (30) days of installation, warranty will begin from the date of shipment. Allied will warrant all parts against defects but not against physical damage or improper installation. All parts being returned "under warranty" must be accompanied with an Allied RMA number. When calling Allied for RMA numbers for SSC main boards, you will be asked for the main board serial number, located on the upper left hand corner inside box, and a description of the problem.

1.3. FCC Warning

This equipment generates, uses, and can radiate radio frequency energy and if not installed and used in accordance with the instruction manual, may cause interference to radio communications. It has been tested and found to comply with the limits for a Class "A" computing device pursuant to Subpart B of Part 15 of the FCC Rules, which are designed to provide reasonable protection against such interference when operated in a commercial environment. Operation of this equipment in a residential area is likely to cause interference, in which case the user, at his own expense, will be required to take whatever measures may be required to correct the interference.

Changes or modifications not expressly approved by the party responsible for compliance could void the user's authority to operate the equipment.

1.4. Overview

The SSC interfaces to the following devices:

Tokheim Dispensers & DPTs

1. Tokheim Dispensers via a 12V Serial interface board connected to the Model 98, or 67 Interface Boxes.
2. Tokheim Generic DPTs, Graphic displays, Debit modules and Cash acceptors via an RS-485 interface board connected to the Model 69 interface box.

Point - Of - Sale (POS)

Generic PC Based Point -Of -Sale Computer via a fully populated RS-232 board. Supporting the ANDI protocol interface.

Tank gauge

1. Veeder Root TLS 250, 350 & 350R or equivalent tank gauge system via a fully populated RS-232 board.
2. Any Tank Gauge system that uses the Veeder Root protocol.

VSAT

Hughes satellite system used to communicate to the Credit Card host via a fully populated RS-232 board.

1.5. Installation Information

1.5.1. Procedures

1. Hardware Installation

- a. Mount SSC unit onto wall.
- b. Route and connect all communication cables as labeled.
Refer to “*Configuration Diagrams*” section.
- c. Apply AC power to unit.

The SSC software will first initialize the hardware and then run some internal diagnostics before starting the application program. To indicate that the software is active, the SSC will display the following:

- d. The prompt will display, ⇒ [SSC System Reset]
[Initializing ...]

SSC will next show the following on the display for several seconds.

- ⇒ [Software Version]
[SSC Warm Start]

SSC will then show the following on the display when ready.

- ⇒ [Software Version]
[Date & Time]

2. Programming steps

- a. Program the dispensers*.
- b. Program the SSC via the POS**.

Note* - Dispenser programming is not within the scope of this manual.

Note** - It is not within the scope of this manual to supply complete step-by-step programming of the POS.

1.6. Configuration Diagram

1.6.1. SSC to Tokheim

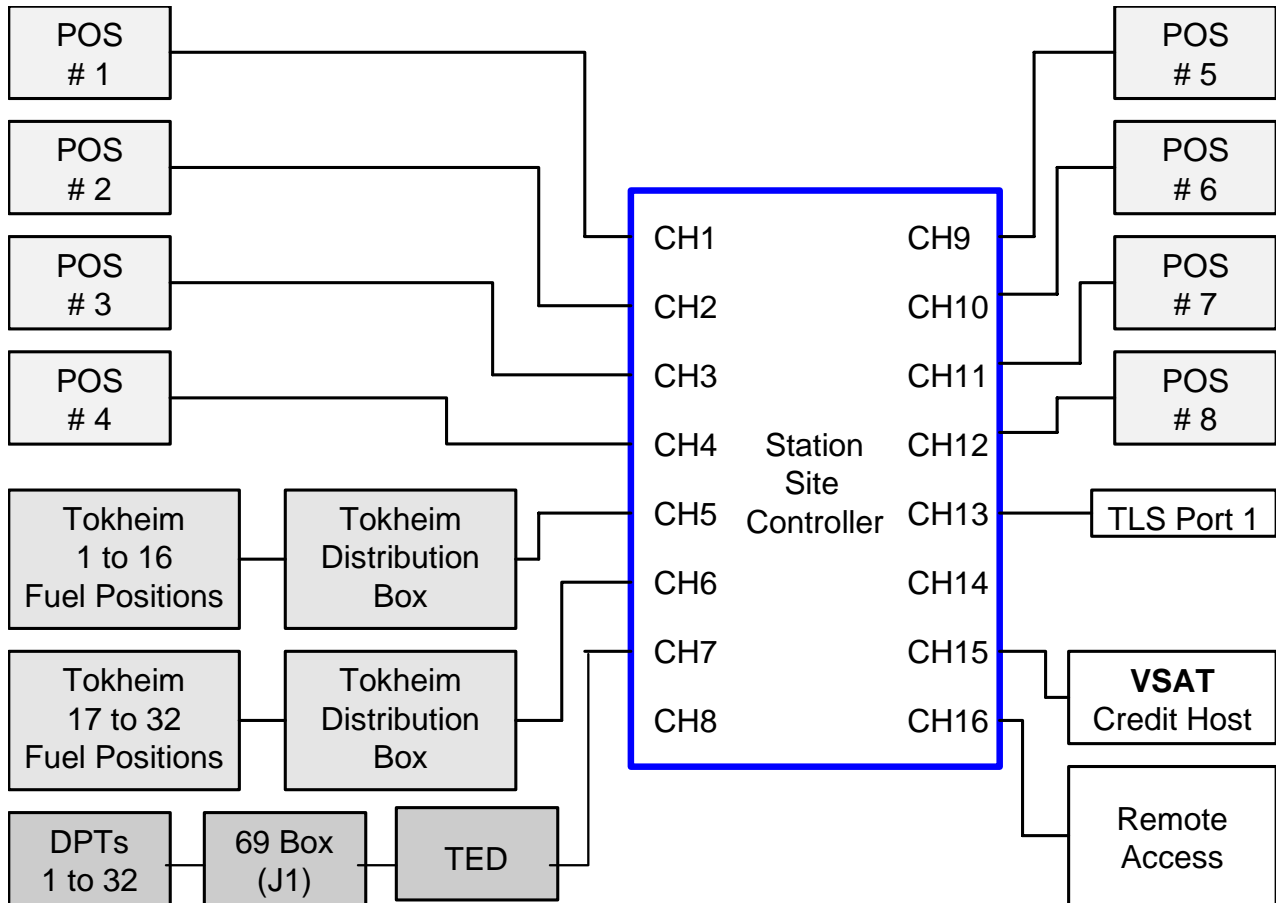

This figure describes an SSC to Tokheim with DPT installation.

Communication Boards

CH1 (POS)	0399-1610-F (RS-232 Fully Populated board)
CH2 (POS) "Optional"	0399-1610-F (RS-232 Fully Populated board)
CH3 (POS) "Optional"	0399-1610-F (RS-232 Fully Populated board)
CH4 (POS) "Optional"	0399-1610-F (RS-232 Fully Populated board)
CH5 (Dispenser)	0399-1512 (12 volt serial interface board)
CH6 (Dispenser) "Optional"	0399-1512 (12 volt serial interface board)
CH7 (DPTs) "Optional"	499-3710 (RS-485 board)
CH9 (POS) "Optional"	0399-1610-F (RS-232 Fully Populated board)
CH10 (POS) "Optional"	0399-1610-F (RS-232 Fully Populated board)
CH11 (POS) "Optional"	0399-1610-F (RS-232 Fully Populated board)
CH12 (POS) "Optional"	0399-1610-F (RS-232 Fully Populated board)
CH13 (TLS Tank Gauge)	0399-1610-F (RS-232 Fully Populated board)
CH15 (VSAT)	0399-1610-F (RS-232 Fully Populated board)
CH16 (Remote Access)	0399-1610-F (RS-232 Fully Populated board)

1.7. Communication Cable Pin Assignments

1.7.1. POS Communication Cables

The SSC supports up to 8 POSs. The POS is a PC Based computer which runs the Point-Of-Sale software. The serial port on the POS can be either a DB-25 or a DB-9 connector.

SSC (CH1 - CH4 & CH9 - CH12) To POS (Serial Port) DB-25 Cable

SSC			POS		
DB25 Female			DB25 Female		
Pins			Pins		
TXD	2	-----	Black	-----	3 RXD
RXD	3	-----	White	-----	2 TXD
RTS	4	-----	Green	-----	5 CTS
CTS	5	-----	Red	-----	4 RTS
GND	7	-----	Blue	-----	7 GND
DSR	6	-----	Brown	-----	11 N/C
					20 DTR
DTR	11	-----	Orange	-----	6 DSR
N/C	20	-----		-----	

SSC (CH1 - CH4 & CH9 - CH12) To POS (Serial Port) DB-9 Cable

SSC			POS		
DB25 Female			DB9 Female		
Pins			Pins		
TXD	2	-----	Black	-----	2 RXD
RXD	3	-----	White	-----	3 TXD
RTS	4	-----	Red	-----	8 CTS
CTS	5	-----	Green	-----	7 RTS
DSR	6	-----	Brown	-----	4 DTR
GND	7	-----	Blue	-----	5 GND
DTR	11	-----	Orange	-----	6 DSR

Shell • ANDI • Tokheim / Installation and Start Up Guide

1.7.2. Tokheim Pump Control (Single)

Up to 2 Tokheim 98 or 67 boxes may be connected on each dispenser communications Channel. Each box must have a 6-wire custom cable which terminates in a 16-position male CPC (Circular Plastic Connector).

This cable connects to CH5 or CH6 and supports up to 16 fueling positions.

Pin-1 (Drain)	Connect to CPC-16
Pin-2 (TxD)	Connect to CPC-2
Pin-3 (RxD)	Connect to CPC-3
Pin-4 (Ground)	Connect to CPC-6
Pin-5 (Em. Stop)	Connect to CPC-10
Pin-6 (Em. Stop)	Connect to CPC-11

SSC (CH5, 6) To the Tokheim Cable

SSC DB25 Female Pins		TOK Circular Connector Pins
1	----- Shield	----- 16
2	----- Brown	----- 2
3	----- Red	----- 3
4	----- Blue	----- 6
5	----- Violet	----- 10
6	----- White	----- 11

1.7.3. Tokheim Pump Control (Dual)

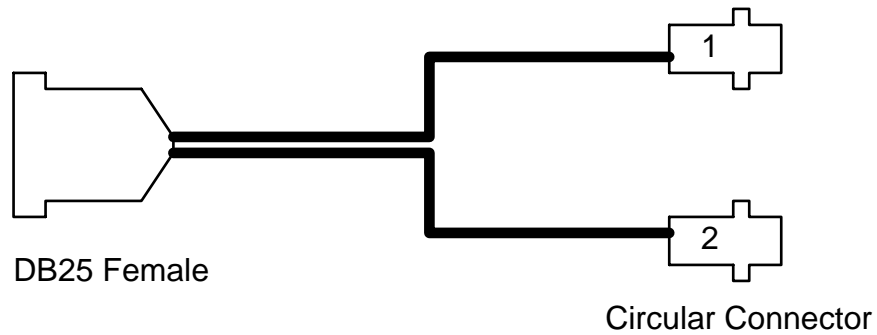

SSC (CH5 ,6) To the Tokheim Dual Cable (2 Dist. Boxes)

SSC DB25 Female Pins		TOK Circular Connector Pins	
1	----- Shield	----- 16	
2	----- Brown	----- 2	
3	----- Red	----- 3	1st
4	----- Blue	----- 6	Cable
5	----- Violet	----- 10	
6	----- White	----- 11	
7	----- Shield	----- 16	
8	----- Brown	----- 2	
9	----- Red	----- 3	2nd
10	----- Blue	----- 6	Cable
11	----- Violet	----- 10	
12	----- White	----- 11	

1.7.4. Tokheim DPT

<u>SSC CH-7</u>	<u>69 Interface Box (J1)</u>	<u>Function</u>
Pin 1	Screw 4	Shield
Pin 2	Screw 2	RS 485 +
Pin 3	Screw 1	RS 485 -
Pin 4	Screw 3	Ground

SSC (CH7) To the Tokheim DPT Cable

SSC DB25 Female Pins			Tokheim #69 Box J1 Connector Screws	
1	-----	Shield	-----	4
2	-----	White	-----	2
3	-----	Red	-----	1
4	-----	Black	-----	3

Note: up to 32 Tokheim DPTs may be connected to the ssc at ch7. A #18 awg 3 conductor shielded cable rated at 600 volts oil and gas resistant must be used for DPT communication, Allied part #28318sf or equivalent.

Caution: The DPT cable cannot be installed in the same conduit as the intercom cable or high voltage lines. Serious damage to the DPT and or the SSC may result if the cable is not installed properly.

1.7.5. TLS-250/350/350R or Equivalent Cable

The SSC uses Channel 13 to interface to the Veeder-Root or Equivalent tank gauge systems. Configure the tank gauge communication parameters as follows:

Baud Rate: 9600 Parity: Odd Stop Bits: 1 Data Bits: 7

On a TLS-250, the communication parameters are set using a rotary switch and DIP switches, (please refer to the TLS 250 manual).

On a TLS-350, the communication parameters are programmed via the TLS keyboard (please refer to TLS 350/350R manual).

SSC (CH13) To the Tank gauge Cable

SSC DB25 Female Pins				Tank gauge DB25 Male Pins
TXD 2	-----	Black	-----	3 RXD
RXD 3	-----	White	-----	2 TXD
RTS 4]			
CTS 5]			
GND 7	-----	Red	-----	7 GND
DSR 6]			
DTR 11]			

1.7.6. Shell VSAT Cable

The SSC uses Channel 15 and 16 to interface with the Shell Credit Host Network and with other remote computers via a Personal Earth Station which is connected to the VSAT.

The Earth station has to be configured (baud-rate, parity, time-outs, etc.) to properly communicate with the SSC. This is done remotely by Shell personnel. The SSC does not configure the Earth Station.

ADS Network configuration:

SSC (CH15 & CH16) To ADS Network VSAT Cable

SSC				PAD / VSAT	
DB25 Female				DB25 Male	
Pins				Pins	
TXD	2	-----	Black	-----	2 RXD
RXD	3	-----	White	-----	3 TXD
RTS	4	-----	Red	-----	4 CTS
CTS	5	-----	Green	-----	5 RTS
DSR	6	-----	Brown	-----	6 DTR
GND	7	-----	Blue	-----	7 GND
DTR	11	-----	Orange	-----	20 DSR

Shell Credit Card Network configuration:

SSC (CH15 & CH16) To Shell Credit Card Network VSAT Cable

SSC				VSAT	
DB25 Female				DB25 Male	
Pins				Pins	
TXD	2	-----	Black	-----	2 RXD
RXD	3	-----	White	-----	3 TXD
CTS	5	-----	Red	-----	8 DCD
DSR	6	-----	Green	-----	6 DTR
GND	7	-----	Brown	-----	7 GND
DTR	11	-----	Blue	-----	20 DSR

2. Programming

2.1.1. Tokheim Addressing

2.1.1.1. Tokheim Model #67 Interface boxes

Tokheim manufactures two model #67 interface boxes, model #67A and #67B. The 67B interface box must be “*downgraded*” to be a #67A in order for it to communicate to an Allied interface box. The 67B interface box will not operate with Allied interface systems.

The downgrade consists of the following changes:

1. Disconnect *J6* and *J8* from the interface motherboard (Part# 316386-1).
2. Disconnect *J3* from the interface power supply board (Part# 421483-1). This board is only in the 67B interface box.
3. *J3*, *J6* and *J8* make up a complete cable assembly. Discard the entire assembly.
4. Disconnect *J4* from the power supply board and connect it into *J6* on the motherboard.

Note: Once this “downgrade” is completed, the 67 box will communicate with the Allied interface.

Shell • ANDI • Tokheim / Installation and Start Up Guide

2.1.1.2. Tokheim Dispensers and DPTs

Two Channels (5 and 6) have been designated to communicate with the Tokheim dispensers. Each Channel can accommodate up to 16 fueling positions. The address of the first fueling position on Channel 5 will be set to address “1”, the second to address “2” etc. If Channel 6 is used, the address of the first fueling position connected on this Channel will also be set to address “1”, the second to address “2” etc. See example .

The SSC uses Channel 7 to communicate with the Tokheim DPTs. The DPT device address must be the same as the fueling position number. Unless it is above 16.

Example:

Fueling Position	Fueling Positions		DPT	
	Address	SSC Channel	Tokheim/Address	SSC Channel
1	1	CH-5	1	CH-7
2	2	CH-5	2	CH-7
3	3	CH-5	3	CH-7
4	4	CH-5	4	CH-7
5	5	CH-5	5	CH-7
6	6	CH-5	6	CH-7
7	7	CH-5	7	CH-7
8	8	CH-5	8	CH-7
9	9	CH-5	9	CH-7
10	10	CH-5	10	CH-7
11	11	CH-5	11	CH-7
12	12	CH-5	12	CH-7
13	13	CH-5	13	CH-7
14	14	CH-5	14	CH-7
15	15	CH-5	15	CH-7
16	16	CH-5	16	CH-7
17	1	CH-6	17	CH-7
18	2	CH-6	18	CH-7
19	3	CH-6	19	CH-7
20	4	CH-6	20	CH-7
21	5	CH-6	21	CH-7
22	6	CH-6	22	CH-7
23	7	CH-6	23	CH-7
24	8	CH-6	24	CH-7
25	9	CH-6	25	CH-7
26	10	CH-6	26	CH-7
27	11	CH-6	27	CH-7
28	12	CH-6	28	CH-7
29	13	CH-6	29	CH-7
30	14	CH-6	30	CH-7
31	15	CH-6	31	CH-7
32	16	CH-6	32	CH-7

2.1.1.3. Tokheim Blending Dispensers

Variable Blenders

The ANDI interfaces to the following types of Tokheim variable blenders:

- Premier Multi hose, multi product blender
- Single hose, multi product blender
- Single hose, multi product + diesel blender

Fixed Blenders

The ANDI interfaces to the following types of Tokheim fixed blenders:

- TCSA blender
- Premier multi hose, multi product blender
- Premier single hose, multi product blender
- One of the above with diesel

Dispenser Programming

Mode 26 of the dispenser programming must be configured correctly for the blend ratios. The programming screen for the dispenser is shown below, for variable blenders.

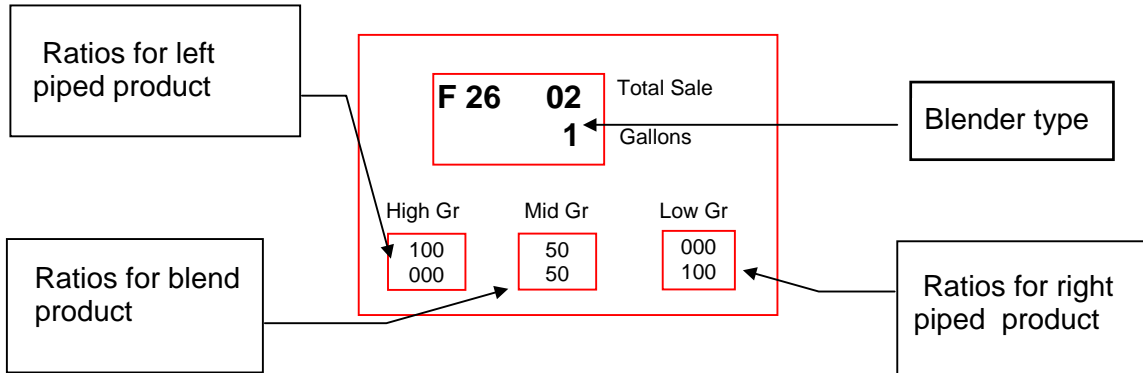

1) In mode 26 on the right side of the gallon display window a **0 ,1 or 2** may be showing in the gallon window. This option sets the **Blender type**.

- 0 = Blender used without ratio verification*
- 1 = Blender used with ratio verification*
- 2 = Blender used with a controller that does not support blenders

* **ratio verification** - The POS ratios must match the dispenser ratios. If the ratios do not match, an error message, “ **Blend Ratio Error**”, will be displayed on the dispenser card reader, if present, when the customer attempts to reset and begin fueling the blended product.

2) Set the blender ratios. Each product has two ratios which are displayed in the PPG windows:

- Top line = ratio of the left piped product
- Bottom line = ratio of the right piped product

As shown in the figure above, the left piped product has 100 % of the high grade and 0 % of the low grade. The right piped product has 0 % of the high grade and 100 % of the low grade.

The blend product allows the left (top) grade to be set, and automatically adjusts the bottom grade ratio so the sum of the ratios equals 100. The **Blended Fuels Ratios** settings in the POS must match the dispenser setting.

Product to Position Mapping

Tokheim dispensers do not require special product to position mapping in the POS **Fueling Point Configuration** menu. The products are set to positions 1 through 3 for a 3 product dispenser, positions 1 through 4 for a 4 product dispenser and positions 1 through 5 for a 5 product dispenser. The table below lists the proper product to position assignment for a 4 product dispenser.

The **blender type** setting for each fueling point must be set properly to one of the values listed below.

2 = Fixed blender

3 = Variable blender or Variable + 1 with the non blended products set as “non” in Mode 26

4 = Variable blender with the non blended product set as a ratio

5 = Variable blender + 1 with the non blended product set as a ratio

Position	Product
1	Low grade
2	Blended product
3	High grade
4	Diesel
5	Not assigned
6	Not assigned
7	Not assigned
8	Not assigned

**** The low grade and the high grade products may be switched depending on the position of the dispenser and the installation of the product lines.***

2.1.1.4. Tokheim Debit

The Tokheim Debit Keypad Modules (TDS+), or Tokheim Encryption Device (TED) must be ordered from Tokheim for a specific Network application. They should be configured by Tokheim for the location. There are no switches or jumpers to be set.

2.2. SSC Parameters Values and Options

The SSC keypad is not used to configure the SSC. The SSC configuration is done by the POS. The POS has to download all required parameters to the SSC. The SSC will start polling the dispensers only after the POS has downloaded station configuration data. If the SSC has not receive the download from the POS you will see [CHXX Await Cnfg.] This means the SSC is waiting to be configured before this Channel becomes active.

Parameters Downloaded from POS:

- DPT Configuration
- Fuel Information
- Product Information
- Car Wash Information
- Cash / Credit Limits
- Mode of Service
- Default Price Level
- Sale Stacking
- Number of fueling points

2.3. Keypads

Type F

(Premier Graphics Keypad – Start button, Soft key, Cancel)

This keypad is supported regardless of keypad setting

Note: Outside Debit and Outside Cash is also supported

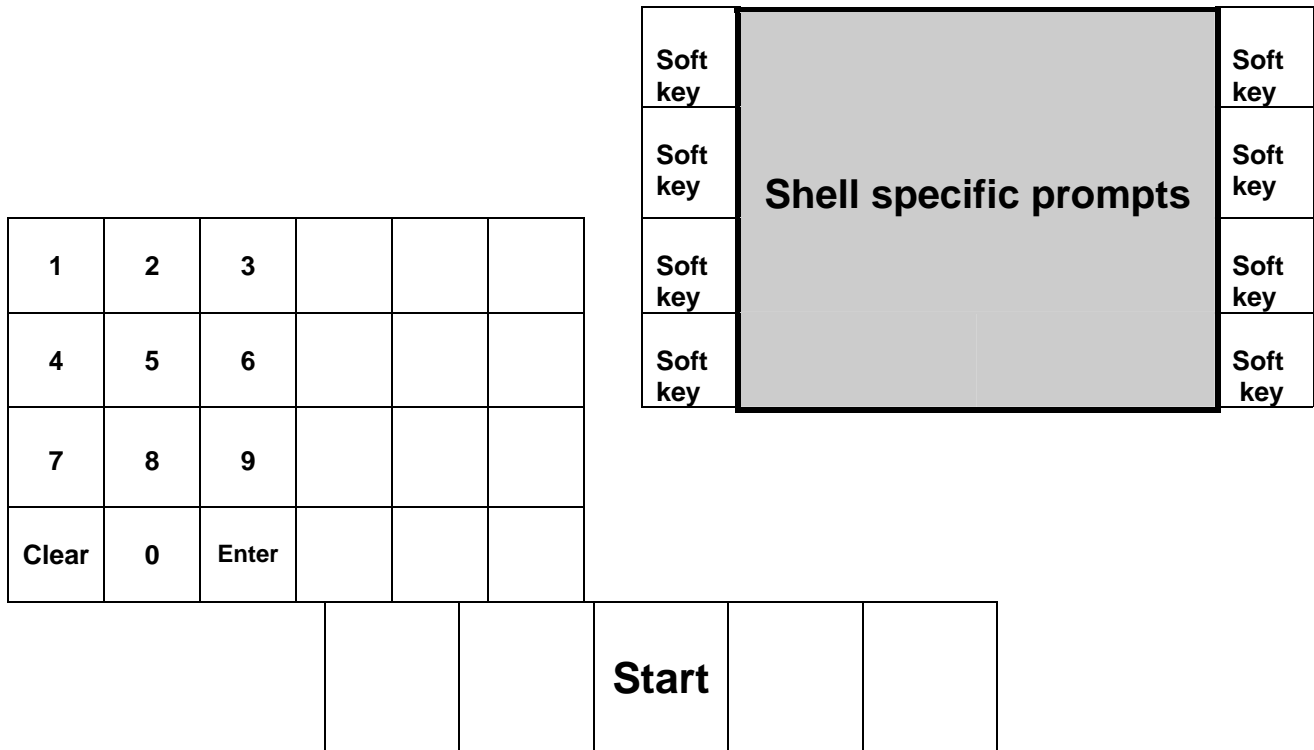

Type H

	1	2	3	Help	Y E S
	4	5	6	Cancel	
	7	8	9		N O
	Clear	0	Enter		

Type K

	1	2	3	Help	Y E S
	4	5	6	Cancel	
	7	8	9		N O
	Clear	0	Enter	Debit	

2.4. Peripheral Devices

2.4.1. Tank Gauge System

The ANDI/SSC uses Channel 13 to interface to the Veeder-Root tank gauge system. The SSC is connected to the Serial board on a TLS 250 or 350, and it may be connected to the DIM board on a 350R.

When the SSC is connected to the DIM board on a TLS 350R it will send real-time fuel transaction data i.e. sale started, sale complete, volume dispensed, meter reading etc. This is accomplished by implementing the Veeder-Root Dispenser Interface Protocol (a proprietary interface defined by Veeder-Root. to the TLS 350R). This will allow the TLS to utilize the AccuChart Automatic Tank Calibration feature for underground storage tank reconciliation.

Configure the TLS-250/350/350R communication parameters as follows:

Baud Rate - 9600, Parity - Odd, Stop Bits - 1, Data Bits - 7

Notes:

On a TLS-250 the communication parameters are set using a rotary switch and some DIP switches, (please refer to the TLS 250 manual).

On a TLS-350/350R the communication parameters are programmed via the TLS keyboard (please refer to the TLS 350/350R manual).

No additional SSC configuration is needed, the SSC will automatically check if it is connected to a DIM card. If not, the SSC will not send any Dispenser Interface commands to the TLS. Communicating with other devices requires POS programming.

To display the TLS link status press the "D" key on the SSC keyboard.

CH-13 Link Up
TLS RS-232 FP

Once the SSC detects it is connected to a DIM board the device name changes to TLS-R

CH-13 Link Up
TLS-R RS-232 FP