

**ALLIED ELECTRONICS, INC**  
**STATION SITE CONTROLLER (SSC)**

**Installation and Start Up Guide**

BP Amoco / ANDI  
to Wayne PIB



ALLIED ELECTRONICS, INC  
2210 FARRAGUT AVENUE  
BRISTOL, PA 19007-0624  
PHONE: 215.785.6200  
FAX: 215.785.0230

COPYRIGHT © 2003 BY ALLIED ELECTRONICS, INC.

Table of Contents

**1. General Information..... 1-1**

1.1. Installation Environment..... 1-1

1.2. Warranty..... 1-1

1.3. FCC Warning ..... 1-2

1.4. Overview ..... 1-3

1.5. Installation Information ..... 1-4

    1.5.1. Procedures ..... 1-4

1.6. Configuration Diagram ..... 1-5

    1.1.1. SSC to Wayne..... 1-5

1.7. Communication Cable Pin Assignments ..... 1-6

    1.7.1. POS Communication Cables..... 1-6

        1.1.2. Wayne PIB/Electronic Central Dispenser Control Cable ..... 1-7

        1.1.3. Wayne CAT ..... 1-7

        1.1.4. Wayne CAT (*With the CAT IF board*) ..... 1-8

    1.7.2. Tank Gauge Cable ..... 1-9

        1.7.2.1. Veeder Root TLS ..... 1-9

        1.7.2.2. Red Jacket ST..... 1-9

    1.7.3. BP Amoco 56K MODEM Cable ..... 1-10

**2. Programming..... 2-1**

2.1. Wayne Addressing ..... 2-1

    2.1.1. Wayne CAT Interface Board..... 2-1

    2.1.2. Wayne Dispensers and CATs ..... 2-2

    2.1.3. Wayne “Vista” Dispensers ..... 2-3

    2.1.4. Wayne “Vista” Blending Dispensers ..... 2-3

2.2. SSC Parameters Values and Options ..... 2-5

2.3. Keypads ..... 2-6

2.4. Peripheral Devices ..... 2-14

    2.4.1. Tank Gauge System..... 2-14

## 1. General Information

### 1.1. Installation Environment

1. The Allied Electronics Station Site Controller (SSC) operates on 115 Vac @60hz,36 watts. The SSC is supplied with approximately 8ft. of 115 Vac power cord, and should be connected to an approved isolated ground receptacle on its own dedicated circuit. The SSC must be installed in a temperature controlled environment (between 32<sup>o</sup> F and 100<sup>o</sup> F).
2. Allied Electronics recommends that the SSC be installed with a UL Listed Power Conditioner to protect against power surges, low voltage (brown outs), and lightning.
3. The SSC must be installed in accordance with the National Electrical Code (NFPA 70), the Automotive and Marine Service Station Code (NFPA 30A), and all state and local electrical codes.
4. The SSC must be installed indoors, above the Class 1, Division 2 Hazardous location.
5. All field wiring (that is, all wiring connected directly to dispensing devices) should be oil and gas resistant, as required by Paragraph 501-13 of the NEC, and should be sealed in accordance with Article 500 of the NEC.
6. For use with peripheral devices which are UL Listed, have an EIA RS232C (or RS422A) communication protocol, and are installed over a hazardous location.

### 1.2. Warranty

The SSC has a one year parts warranty only, from date of installation, which can either be phoned in or submitted using the warranty/registration card enclosed in every SSC. If the start up information is not registered with our office within thirty (30) days of installation, warranty will begin from the date of shipment. Allied will warrant all parts against defects but not against physical damage or improper installation. All parts being returned "under warranty" must be accompanied with an Allied RMA number. When calling Allied for RMA numbers for SSC main boards, you will be asked for the main board serial number, located on the upper left hand corner inside box, and a description of the problem.

### **1.3. FCC Warning**

This equipment generates, uses, and can radiate radio frequency energy and if not installed and used in accordance with the instruction manual, may cause interference to radio communications. It has been tested and found to comply with the limits for a Class "A" computing device pursuant to Subpart B of Part 15 of the FCC Rules, which are designed to provide reasonable protection against such interference when operated in a commercial environment. Operation of this equipment in a residential area is likely to cause interference, in which case the user, at his own expense, will be required to take whatever measures may be required to correct the interference.

Changes or modifications not expressly approved by the party responsible for compliance could void the user's authority to operate the equipment.

## **1.4. Overview**

**The SSC interfaces to the following devices:**

### **Wayne Dispensers & CATs**

1. Wayne Dispensers via a 7-wire Fully Populated RS-232 communication board connected to the Wayne PIB which is located in the Electronic Central.
2. Wayne CATs, Graphic displays, Debit MSM modules and Cash acceptors via an RS-485 interface board connected to either a J-Box or the CAT IF board.

### **Point - Of - Sale (POS)**

Generic PC Based Point -Of -Sale Computer via a fully populated RS-232 board. Supporting the ANDI protocol interface.

### **Tank gauge**

1. Veeder Root TLS 250, 350 & 350R or equivalent tank gauge system via a fully populated RS-232 board.
2. Any Tank Gauge system that uses the Veeder Root protocol.

### **Modem**

Dial-up 56K Modem used to communicate to the Credit Card host via a fully populated RS-232 board.

## 1.5. Installation Information

### 1.5.1. Procedures

#### 1. Hardware Installation

- a. Mount SSC unit onto wall.
- b. Route and connect all communication cables as labeled.  
Refer to “*Configuration Diagrams*” section.
- c. Apply AC power to unit.

The SSC software will first initialize the hardware and then run some internal diagnostics before starting the application program. To indicate that the software is active, the SSC will display the following:

- d. The prompt will display, ⇒ [SSC System Reset]  
[Initializing ...]

SSC will next show the following on the display for several seconds.

- ⇒ [Software Version]  
[SSC Warm Start ]

SSC will then show the following on the display when ready.

- ⇒ [Software Version]  
[ Date & Time ]

#### 2. Programming steps

- a. Program the dispensers\*.
- b. Program the SSC via the POS\*\*.

**Note\*** - Dispenser programming is not within the scope of this manual.

**Note\*\*** - It is not within the scope of this manual to supply complete step-by-step programming of the POS.

1.6. Configuration Diagram

1.1.1. SSC to Wayne

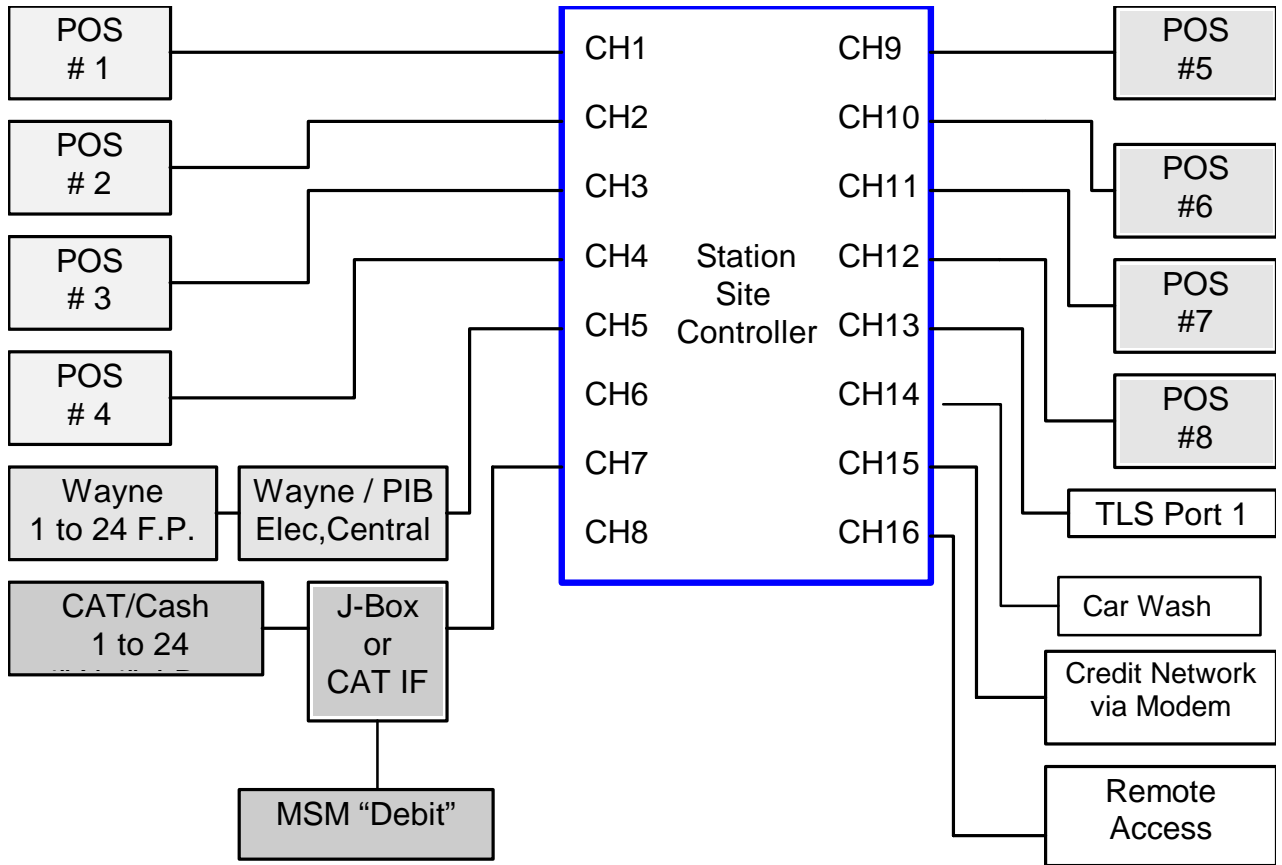

This figure describes an SSC to Wayne with CAT installation.

**Communication Boards**

CH1 (POS)	.....0399-1610-F (RS-232 Fully Populated board)
CH2 (POS) "Optional"	.....0399-1610-F (RS-232 Fully Populated board)
CH3 (POS) "Optional"	.....0399-1610-F (RS-232 Fully Populated board)
CH4 (POS) "Optional"	.....0399-1610-F (RS-232 Fully Populated board)
CH5 (Dispenser)	.....0399-1610-F (RS-232 Fully Populated board)
CH7* (CAT/Cash)	.....499-2710 or 499-3710 (RS485 board)
CH9 (POS) "Optional"	.....0399-1610-F (RS-232 Fully Populated board)
CH10 (POS) "Optional"	.....0399-1610-F (RS-232 Fully Populated board)
CH11 (POS) "Optional"	.....0399-1610-F (RS-232 Fully Populated board)
CH12 (POS) "Optional"	.....0399-1610-F (RS-232 Fully Populated board)
CH14 (Car Wash)	.....0399-1610-F (RS-232 Fully Populated board)
CH13 (TLS Tank Gauge)	.....0399-1610-F (RS-232 Fully Populated board)
CH15 (Network via Modem)	.....0399-1610-F (RS-232 Fully Populated board)
CH16 (Remote Access)	.....0399-1610-F (RS-232 Fully Populated board)

\* If a CAT IF board is present the 499-3710 RS-485 board must be used.

**1.7. Communication Cable Pin Assignments**

**1.7.1. POS Communication Cables**

The SSC supports up to 8 POSs. The POS is a PC Based computer which runs the Point-Of-Sale software. The serial port on the POS can be either a DB-25 or a DB-9 connector.

**SSC (CH1 - CH4 & CH9 - CH12) To POS (Serial Port) DB-25 Cable**

SSC			POS		
DB25 Female			DB25 Female		
Pins			Pins		
TXD	2	-----	Black	-----	3 RXD
RXD	3	-----	White	-----	2 TXD
RTS	4	-----	Green	-----	5 CTS
CTS	5	-----	Red	-----	4 RTS
GND	7	-----	Blue	-----	7 GND
DSR	6	-----	Brown	-----	11 N/C
					20 DTR
DTR	11	-----	Orange	-----	6 DSR
N/C	20	-----		-----	

**SSC (CH1 - CH4 & CH9 - CH12) To POS (Serial Port) DB-9 Cable**

SSC			POS		
DB25 Female			DB9 Female		
Pins			Pins		
TXD	2	-----	Black	-----	2 RXD
RXD	3	-----	White	-----	3 TXD
RTS	4	-----	Red	-----	8 CTS
CTS	5	-----	Green	-----	7 RTS
DSR	6	-----	Brown	-----	4 DTR
GND	7	-----	Blue	-----	5 GND
DTR	11	-----	Orange	-----	6 DSR

**1.1.2. Wayne PIB/Electronic Central Dispenser Control Cable**

The SSC uses a Fully Populated RS232 communication board in Channel 5 to interface to the Wayne PIB/dispensers. Up to 24 fueling positions may be connected. Channel 5 must have a 7-wire custom cable which terminates in a female DB-25 connector.

**SSC (CH5) To the Wayne Cable (Female DB-25)**

SSC DB25 Female Pins				Wayne/PIB DB25 Female Pins
TXD 2	-----	Black	-----	3 RXD
RXD 3	-----	White	-----	2 TXD
RTS 4	-----	Red	-----	5 CTS
CTS 5	-----	Green	-----	4 RTS
DSR 6	-----	Orange	-----	11 DTR
N/C 8	-----		-----	20 N/C
GND 7	-----	Brown	-----	7 GND
DTR 11	-----	Blue	-----	8 DCD
N/C 20	-----		-----	6 N/C

**1.1.3. Wayne CAT**

Up to 24 Wayne CATs may be connected to the SSC at Channel 7.

**SSC (CH7) To the Wayne CAT Cable**

SSC DB25 Female Pins				4" X 4" J - Box
1	-----	Shield	-----	Drain
2	-----	Red	-----	RS-485 +
3	-----	Black	-----	RS-485 -

**Note:** a #18 awg 2 conductor shielded cable rated at 600 volts oil and gas resistant must be used for cat communication, Allied part #28218 or equivalent.

**Caution:** The CAT cable cannot be installed in the same conduit as the intercom cable or high voltage lines. Serious damage to the CAT and or the SSC may result if the cable is not installed properly.

1.1.4. Wayne CAT (With the CAT IF board)

Up to 24 Wayne CATs may be connected to the SSC via the Wayne CAT IF board which is located inside of the Electronic Central. Channel 7 of the SSC will connect to the Wayne CAT IF board via the DB25 connector which is located on the outside of the EC.

SSC (CH7) To the Wayne CAT IF Cable

SSC DB25 Female Pins				CAT IF/EC DB25 Male Pins
(Shield) 1	-----	Shield	-----	N/C
(+RT) 2	-----	Red	-----	23 (RS-485 +)
(-RT) 3	-----	Green	-----	24 (RS-485 -)
(GND) 3	-----	Black	-----	7 (GND)
(TXENA) 5	-----	White	-----	21 (TX485EN)

**Note:** when the cat if board is used there is no need to use the #18 awg 2 conductor shielded cable rated at 600 volts oil and gas resistant . The shielded cable which is specified above will be sufficient.

**1.7.2. Tank Gauge Cable**

The SSC uses Channel 13 to interface to the Veeder-Root or Equivalent tank gauge systems. Configure the tank gauge communication parameters as follows:

**Baud Rate: 9600    Parity: Odd    Stop Bits: 1    Data Bits: 7**

**1.7.2.1. Veeder Root TLS**

On a TLS-250, the communication parameters are set using a rotary switch and DIP switches, (please refer to the TLS 250 manual).

On a TLS-350, the communication parameters are programmed via the TLS keyboard (please refer to TLS 350/350R manual).

**SSC (CH13) Cable to the TLS**

SSC DB25 Female Pins				TLS DB25 Male Pins
TXD 2	-----	Black	-----	3 RXD
RXD 3	-----	White	-----	2 TXD
RTS 4	┌			
CTS 5	└			
GND 7	-----	Red	-----	7 GND
DSR 6	┌			
DTR 11	└			

**1.7.2.2. Red Jacket ST**

**SSC (CH13) Cable to the Red Jacket "ST" tank gauge**

SSC DB25 Female Pins				Red Jacket DB9 Female Pins
TXD 2	-----	Black	-----	2 RXD
RXD 3	-----	White	-----	3 TXD
CTS 5	-----	Green	-----	7 RTS
GND 7	-----	Red	-----	5 GND
DSR 6	┌			
DTR 11	└			

**1.7.3. BP Amoco 56K MODEM Cable**

The SSC uses Channel 15 and 16 to interface with the BP Amoco Credit Host Network and with other remote computers via a Personal Earth Station which is connected to the 56K MODEM.

The Earth station has to be configured (baud-rate, parity, time-outs, etc.) to properly communicate with the SSC. This is done remotely by BP Amoco personnel. The SSC does not configure the Earth Station.

***As of November 7, 2000 BP Amoco is using the following original Texaco PAD cable configuration for the 56K MODEM.***

**SSC (CH15 & CH16) To the BP Amoco 56K MODEM Cable**

SSC DB25 Female Pins				56K MODEM DB25 Male Pins
TXD 2	-----	Black	-----	2 RXD
RXD 3	-----	White	-----	3 TXD
RTS 4	-----	Red	-----	4 CTS
CTS 5	-----	Green	-----	5 RTS
DSR 6	-----	Brown	-----	6 DTR
GND 7	-----	Blue	-----	7 GND
DTR 11	-----	Orange	-----	20 DSR

## 2. Programming

### 2.1. Wayne Addressing

#### 2.1.1. Wayne CAT Interface Board

The following is a list of the jumper settings for the Wayne CAT IF board when used with the ANDI.

Jumper	Position
JP1, JP2, JP4 – JP6, JP10, JP11 – JP28, JP30, JP31	1 & 2
JP3, JP8, JP9, JP29	None
JP7	2 & 3

**2.1.2. Wayne Dispensers and CATs**

Channel 5 has been designated to communicate with the Wayne dispensers via the PIB, which must be set to 1200 or 9600 baud, and can communicate with up to 24 fueling positions.

The SSC uses Channel 7 to communicate with the Wayne CATs. A communication cable connects Channel 7 to a junction box for connection to the CATs. If a CAT IF board is present it is installed in the Electronic Central. In this case all of the CATs are connected to the motherboard inside of the EC.

**Example:**

Fueling Position	Fueling Positions		CAT	
	Address	SSC Channel	Address	SSC Channel
1	1	CH-5	1	CH-7
2	2	CH-5	2	CH-7
3	3	CH-5	3	CH-7
4	4	CH-5	4	CH-7
5	5	CH-5	5	CH-7
6	6	CH-5	6	CH-7
7	7	CH-5	7	CH-7
8	8	CH-5	8	CH-7
9	9	CH-5	9	CH-7
10	10	CH-5	10	CH-7
11	11	CH-5	11	CH-7
12	12	CH-5	12	CH-7
13	13	CH-5	13	CH-7
14	14	CH-5	14	CH-7
15	15	CH-5	14	CH-7
16	16	CH-5	16	CH-7
17	17	CH-5	17	CH-7
18	18	CH-5	18	CH-7
19	19	CH-5	19	CH-7
20	20	CH-5	20	CH-7
21	21	CH-5	21	CH-7
22	22	CH-5	22	CH-7
23	23	CH-5	23	CH-7
24	24	CH-5	24	CH-7

### 2.1.3. Wayne “Vista” Dispensers

The following parameters must be set in the Wayne “Vista” dispensers and in the 2400 console in order for the system to function correctly.

Vista Dispenser		
Model	Option #2 (Macro)	Option #51 (Blend Ratios)
V390 D1, (non-blend)	5	N/A
V395 D1, (variable blend)	13	Must match mode 17 in the 2400 console
V580 D1, (variable blend)	10	Must match mode 17 in the 2400 console
V580 D3, (variable blend)	11	Must match mode 17 in the 2400 console
V590 Uni-hose, (fixed blend)	10	Must match mode 17 in the 2400 console
V590 D1, (fixed blend)	7	Must match mode 17 in the 2400 console

2400 console		
Mode	Sub-mode	Setting
03 (FP to tank assignment)	FP #	Pure products, ex. (0534, 0540)
18 (Grade to position assignment)	FP #	POS FP config. must match mode 18
17 (Blend ratio to grade)	06 (blended product)	Must match option 51 in the dispenser

### 2.1.4. Wayne “Vista” Blending Dispensers

#### Variable Blenders

The ANDI interfaces to the following Wayne variable blenders.

- 580 D1** - Single hose. Multi product dispenser without diesel.
- 580 D3** - Single hose. Multi product dispenser without diesel.
- 395** - Single hose + 1. Multi product dispenser with diesel.

#### Fixed Blenders

The ANDI interfaces to the following Wayne fixed blenders.

- 590** - Multi hose, multi product dispenser without diesel.
- 590U** - Single hose, multi product dispenser without diesel. Uses the same configuration as the 580.

**Dispenser and 2400 Console Settings**

For the Wayne blenders to operate properly, several options must be set at the dispenser, at the Decade 2400 console and also at the POS.

**1- Dispenser Macro**

The dispenser options are set via a macro. Below are the proper macro settings for the variable blenders.

Model Type	Macro Setting
590	7
395	13
580 D1 & 590U	10
580 D3	11

**2- 2400 Console Programming**

Additional programming parameters must be set via the Decade 2400 console for proper dispenser operation.

a) Set Mode 18 for each fueling point. Mode 18 is the **Grade to Position** assignment for each fueling point. The table below summarizes proper mode setting for each type of blending dispenser.

Model Type	Mode 18 Setting
590	0465000
395	1005640
580 D1 & 590U	0050604
580 D3	0056400

b) Set Mode 03 for each fueling point. Mode 03 programs the **Grade** assignment for each fueling point. Below summarizes the proper setting for each type of blending dispenser.

Model Type	Mode 03 Setting
590	0540
395	0541
580 D1 & 590U	0540
580 D3	0540

c) Set Mode 17, sub- mode 6 (**blend grade**). This sets the Blend Ratio for product 6. This blend ratio must match the ratio that is set at the dispenser in option 51 and also at the POS in the **Blended Fuels Ratios Menu**.

## 2.2. SSC Parameters Values and Options

The SSC keypad is not used to configure the SSC. The SSC configuration is done by the POS. The POS has to download all required parameters to the SSC. The SSC will start polling the dispensers only after the POS has downloaded station configuration data. If the SSC has not receive the download from the POS you will see [CHXX Await Cnfg.] This means the SSC is waiting to be configured before this Channel becomes active.

### Parameters Downloaded from POS:

- DPT Configuration
- Fuel Information
- Product Information
- Car Wash Information
- Cash / Credit Limits
- Mode of Service
- Default Price Level
- Sale Stacking
- Number of fueling points

2.3. Keypads

Type 1

1	2	3		Pay Outside Credit
4	5	6	Pay Inside Cash	Pay Inside Credit
7	8	9	No	Yes
Clear	0	Enter	Help	Cancel

Type 2

1	2	3		Pay Outside
4	5	6		Pay Inside
7	8	9	No	Yes
Clear	0	Enter	Help	Cancel

**Type 3**

1	2	3	Pay Outside Debit	Pay Outside Credit
4	5	6	Pay Inside Cash	Pay Inside Credit
7	8	9	No	Yes
Clear	0	Enter	Help	Cancel

**Type 4**

1	2	3	Pay Inside	Pay Outside
4	5	6		
7	8	9	No	Yes
Clear	0	Enter	Help	Cancel

**Type 6**

1	2	3	Yes
4	5	6	No
7	8	9	Help
Clear	0	Enter	Cancel

**Type 7**

1	2	3	Yes
4	5	6	No
7	8	9	
Clear	0	Enter	Cancel

**Type 8**

1	2	3	Yes
4	5	6	No
7	8	9	Help
Clear	0	Cancel	Enter

**Type 9**

1	2	3		
4	5	6		
7	8	9	Yes	Help
Clear	0	Enter	No	Cancel

**Type A**

1	2	3		Pay Outside Credit
4	5	6		Pay Inside
7	8	9	No	Yes
Clear	0	Enter	Help	Cancel

**Type B**

1	2	3	Pay Outside Debit	Pay Outside Credit
4	5	6		Pay Inside
7	8	9	No	Yes
Clear	0	Enter	Help	Cancel

**Type C**

1	2	3		Pay Outside Credit
4	5	6	Pay Outside Cash	Pay Inside
7	8	9	No	Yes
Clear	0	Enter	Help	Cancel



**Type D**

1	2	3	Pay Outside Debit	Pay Outside Credit
4	5	6	Pay Outside Cash	Pay Inside
7	8	9	No	Yes
Clear	0	Enter	Help	Cancel

**Type E**

1	2	3	Yes
4	5	6	No
7	8	9	Help
Clear	0	Enter	Cancel

**Type F**

1	2	3	Yes
4	5	6	No
7	8	9	Cancel
Clear	0	Enter	Debit

**Type G**

1	2	3	Pay Outside Debit	Pay Outside Credit
4	5	6	Pay Outside Cash	Pay Inside
7	8	9	No	Yes
Clear	0	Enter	Help	Cancel

**Type H**

1	2	3	Credit	
4	5	6	Debit	
7	8	9	No	Yes
Clear	0	Enter	Help	Clear/Cancel

**Type I (FCL)**

1	2	3	Yes	French
4	5	6	No	
7	8	9	Help	
Clear	0	Enter	Cancel	

Type J

1	2	3	Pay Outside	
4	5	6	Pay Inside	
7	8	9	Yes	Help
Clear	0	Enter	No	Cancel

## 2.4. Peripheral Devices

### 2.4.1. Tank Gauge System

The ANDI/SSC uses Channel 13 to interface to the Veeder-Root tank gauge system. The SSC is connected to the Serial board on a TLS 250 or 350, and it may be connected to the DIM board on a 350R.

When the SSC is connected to the DIM board on a TLS 350R it will send real-time fuel transaction data i.e. sale started, sale complete, volume dispensed, meter reading etc. This is accomplished by implementing the Veeder-Root Dispenser Interface Protocol (a proprietary interface defined by Veeder-Root. to the TLS 350R). This will allow the TLS to utilize the AccuChart Automatic Tank Calibration feature for underground storage tank reconciliation.

Configure the TLS-250/350/350R communication parameters as follows:

**Baud Rate - 9600, Parity - Odd, Stop Bits - 1, Data Bits - 7**

#### Notes:

On a TLS-250 the communication parameters are set using a rotary switch and some DIP switches, (please refer to the TLS 250 manual).

On a TLS-350/350R the communication parameters are programmed via the TLS keyboard (please refer to the TLS 350/350R manual).

No additional SSC configuration is needed, the SSC will automatically check if it is connected to a DIM card. If not, the SSC will not send any Dispenser Interface commands to the TLS. Communicating with other devices requires POS programming.

To display the TLS link status press the "D" key on the SSC keyboard.

```
CH-13 Link Up
TLS  RS-232 FP
```

Once the SSC detects it is connected to a DIM board the device name changes to TLS-R

```
CH-13 Link Up
TLS-R RS-232 FP
```