

ALLIED ELECTRONICS, INC
STATION SITE CONTROLLER (SSC)

Installation and Start Up Guide

ARCO / ANDI
to Wayne Direct



ALLIED ELECTRONICS, INC
2210 FARRAGUT AVENUE
BRISTOL, PA 19007-0624
PHONE: 215.785.6200
FAX: 215.785.0230

COPYRIGHT © 2004 BY ALLIED ELECTRONICS, INC.

Table of Contents

1. General Information.....	1-1
1.1. Installation Environment.....	1-1
1.2. Warranty	1-1
1.3. FCC Warning	1-2
1.4. Overview	1-3
2. Installation Information.....	2-1
2.1. Procedures.....	2-1
2.2. Configuration Diagrams	2-2
2.2.1. SSC to Wayne Direct via the Wayne Data box with the Schlumberger/Tokheim PIC ...	2-2
2.2.2. SSC to Wayne Direct via the Gilbarco “D” Box with the Schlumberger/Tokheim PIC ...	2-3
2.2.3. SSC to Wayne Direct via the Wayne Data Box with the Helix PIC	2-4
2.2.4. SSC to Wayne Direct via the Gilbarco “D” Box with the Helix PIC	2-5
2.3. Cable Pin Assignments	2-6
2.3.1. POS Communication Cables.....	2-6
2.3.2. Wayne Direct Dispenser Control Cable.....	2-7
2.3.2.1. Wayne Direct to the Wayne Data Distribution Box.....	2-7
2.3.2.2. Wayne Direct to the Gilbarco Distribution Box	2-8
2.3.3. Wayne Direct CAT via the Allied Isolation Box	2-9
2.3.4. Wayne Direct CAT via a Junction box.....	2-9
2.3.5. Schlumberger/Tokheim PIC via the (SAM/SSM).....	2-10
2.3.6. Helix PIC via the Allied Isolation Box.....	2-11
2.3.6.1. SSC/Helix to the Allied Isolation Box.....	2-11
3. Programming	3-1
3.1. Wayne Direct Addressing.....	3-1
3.1.1. Wayne Direct Dispensers and CATs	3-1
3.1.2. Wayne “Vista” Dispensers.....	3-2
3.1.3. Wayne “Vista” Blending Dispensers	3-2
3.1.4. Wayne Blending Quick Reference Guide	3-7
3.2. PIC Addressing (Payment Island Cashier).....	3-8
3.2.1. Schlumberger/Tokheim PIC	3-8
3.2.1.1. Schlum/Tok Access/Security Module (SAM/SSM) for Debit.....	3-8
3.2.2. Helix PIC	3-9
3.3. SSC Parameters Values and Options	3-9
3.4. Keypads	3-10
3.4.1. Wayne	3-10
3.4.2. Schlumberger PIC	3-16
3.5. Peripheral Devices	3-17
3.5.1. Tank Gauge Systems.....	3-17

1. General Information

1.1. Installation Environment

1. The Allied Electronics Station Site Controller (SSC) operates on 115 VAC @60hz,36 watts. The SSC is supplied with approximately 8ft. of 115 VAC power cord, and should be connected to an approved isolated ground receptacle on its own dedicated circuit. The SSC must be installed in a temperature controlled environment (between 32^o F and 100^o F).
2. Allied Electronics recommends that the SSC be installed with a UL Listed Escort Power Conditioner to protect against power surges, low voltage (brown outs), and lightning.
3. The SSC must be installed in accordance with the National Electrical Code (NFPA 70), the Automotive and Marine Service Station Code (NFPA 30A), and all state and local electrical codes.
4. The SSC must be installed indoors, above the Class 1, Division 2 Hazardous location.
5. All field wiring (that is, all wiring connected directly to dispensing devices) should be oil and gas resistant, as required by Paragraph 501-13 of the NEC, and should be sealed in accordance with Article 500 of the NEC.
6. For use with peripheral devices which are UL Listed, have an EIA RS232C (or RS422A) communication protocol, and are installed over a hazardous location.

1.2. Warranty

The SSC has a one year parts warranty only, from date of installation, which can either be phoned in or submitted using the warranty/registration card enclosed in every SSC. If the start up information is not registered with our office within thirty (30) days of installation, warranty will begin from the date of shipment. Allied will warrant all parts against defects but not against physical damage or improper installation. All parts being returned "under warranty" must be accompanied with a Allied RMA number. When calling Allied for RMA numbers for SSC main boards, you will be asked for the main board serial number, located on the upper left hand corner inside box, and a description of the problem.

1.3. FCC Warning

This equipment generates, uses, and can radiate radio frequency energy and if not installed and used in accordance with the instruction manual, may cause interference to radio communications. It has been tested and found to comply with the limits for a Class "A" computing device pursuant to Subpart B of Part 15 of the FCC Rules, which are designed to provide reasonable protection against such interference when operated in a commercial environment. Operation of this equipment in a residential area is likely to cause interference, in which case the user, at his own expense, will be required to take whatever measures may be required to correct the interference.

Changes or modifications not expressly approved by the party responsible for compliance could void the user's authority to operate the equipment.

1.4. Overview

The SSC interfaces to the following devices:

See the “Technical Tips” section for dispenser models that are supported.

Wayne Direct, Dispensers & CATs

1. Wayne Dispensers via a 45 ma current loop board which can be connected to either a Wayne Data distribution box or a Gilbarco Universal distribution Box.
2. Wayne CATs, Graphic displays, Debit MSM modules and Cash acceptors via a 4 channel RS-485 interface board which can be connected to the Allied Isolation box or can be hard wired directly to the individual CATs via a junction box.

Schlumberger/Tokheim Dispensers and PIC (Payment Island Cashier)

1. Schlumberger PIC via a fully populated RS232 board connected to the SAM/SSM (Schlumberger Security Module).

Point - Of - Sale (POS)

ARCO PC Based Point -Of -Sale Computer via a fully populated RS-232 board.

Helix PIC (Payment Island Cashier)

Helix PIC via a 4-channel RS-485 interface board that is connected to the Allied Isolation box or can be hard wired directly to the individual CATs via a junction box.

Tank gauge

1. Veeder Root TLS 250, 350 & 350R or equivalent tank gauge system via a fully populated RS-232 board.
2. Any Tank Gauge system that uses the Veeder Root protocol.

2. Installation Information

2.1. Procedures

1. Hardware Installation

- a. Mount SSC unit onto wall.
- b. Route and connect all communication cables as labeled.
Refer to “*Configuration Diagrams*” section.
- c. Apply AC power to unit.

The SSC software will first initialize the hardware and then run some internal diagnostics before starting the application program. To indicate that the software is active, the SSC will display the following:

- d. The prompt will display, ⇒ [SSC System Reset]
[Initializing ...]

SSC will next show the following on the display for several seconds.

- ⇒ [Software Version]
[SSC Warm Start]

SSC will then show the following on the display when ready.

- ⇒ [Software Version]
[Date & Time]

If you have these prompts, then proceed to next step, if not refer to the “*Power-Up Diagnostics*” of the Technical Tips section.

2. Programming steps

- a. Program the dispensers*.
- b. Program the SSC via the POS**.

Note* - Dispenser programming is not within the scope of this manual.

Note** - It is not within the scope of this manual to supply complete step-by-step programming of the POS.

2.2. Configuration Diagrams

2.2.1. SSC to Wayne Direct via the Wayne Data box with the Schlumberger/Tokheim PIC

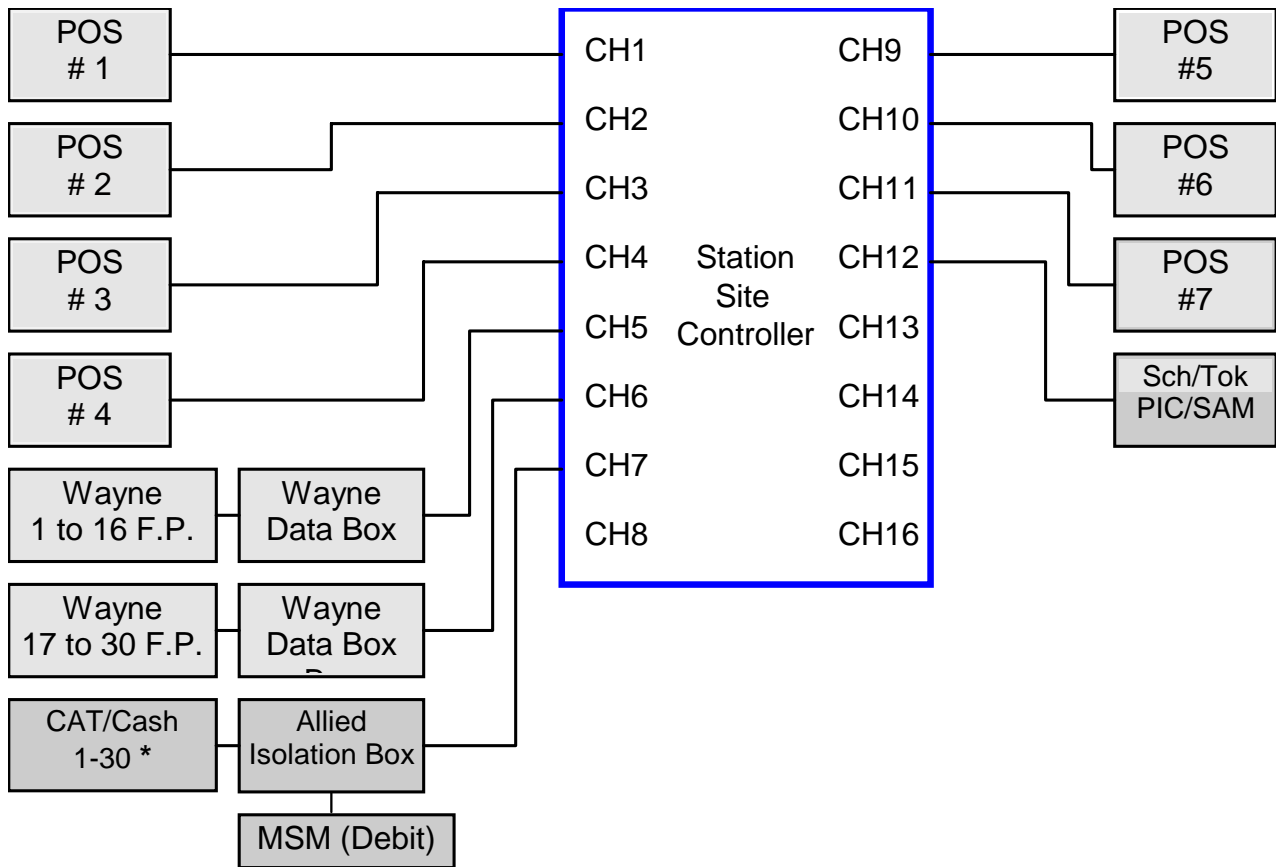

This figure describes an SSC to Wayne Direct with CAT installation.

Communication Boards

CH1 (POS)	399-1610-F (RS-232 Fully Populated board)
CH2 (POS) "Optional"	399-1610-F (RS-232 Fully Populated board)
CH3 (POS) "Optional"	399-1610-F (RS-232 Fully Populated board)
CH4 (POS) "Optional"	399-1610-F (RS-232 Fully Populated board)
CH5 (Dispenser)	499-2410 (Current loop board)
CH6 (Dispenser)	499-2410 (Current loop board)
CH7 (CAT/Cash)	499-4710 (4 channel RS485 board)
CH9 (POS) "Optional"	399-1610-F (RS-232 Fully Populated board)
CH10 (POS) "Optional"	399-1610-F (RS-232 Fully Populated board)
CH11 (POS) "Optional"	399-1610-F (RS-232 Fully Populated board)
CH12 (Sch/Tokheim PIC)	399-1610-F (RS-232 Fully Populated board)

* Up to 30 CATs may be connected to the SSC at channel 7. If Debit is required then only 29 CATs are supported because the MSM is configured as number 30.

2.2.2. SSC to Wayne Direct via the Gilbarco “D” Box with the Schlumberger/Tokheim PIC

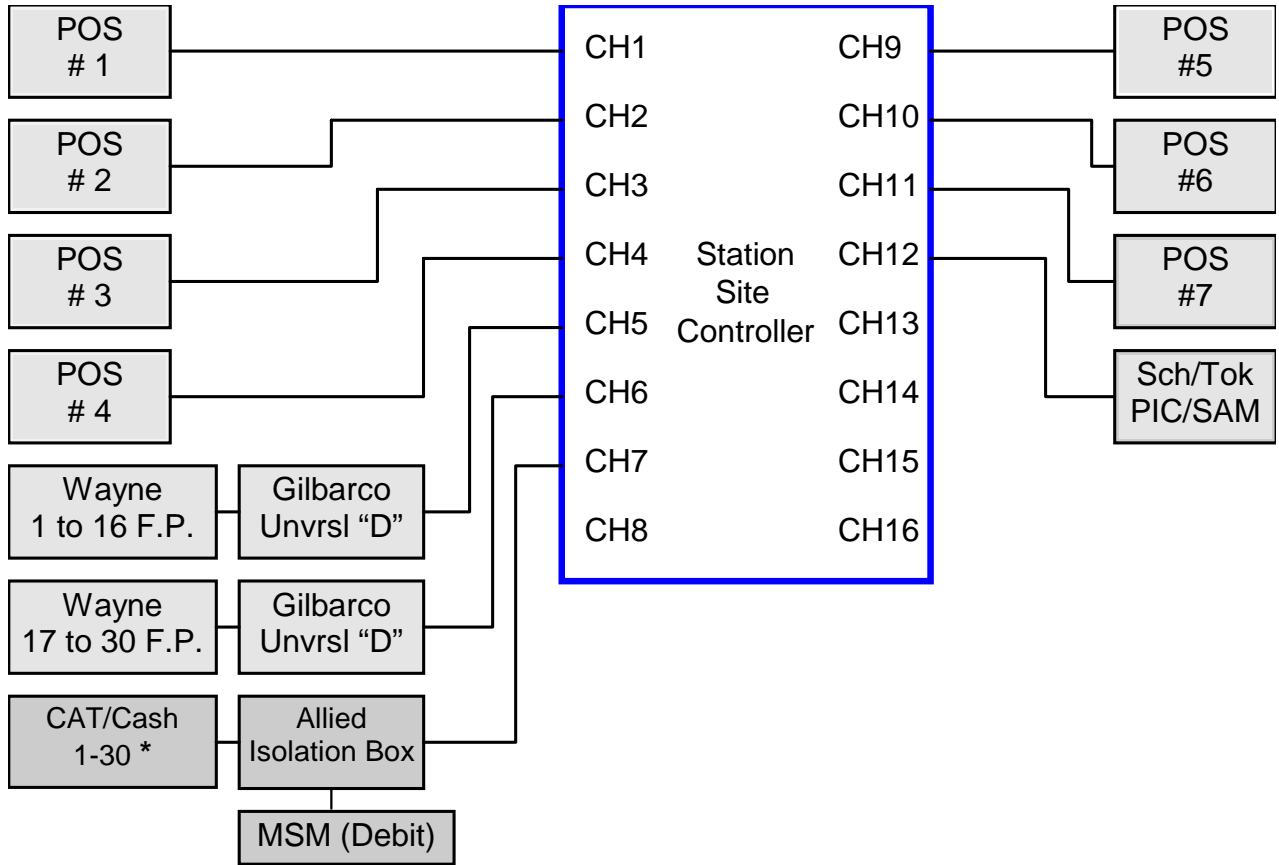

This figure describes an SSC to Wayne Direct via the Gilbarco “D” box with CATs.

Communication Boards

CH1 (POS)	399-1610-F (RS-232 Fully Populated board)
CH2 (POS) “Optional”	399-1610-F (RS-232 Fully Populated board)
CH3 (POS) “Optional”	399-1610-F (RS-232 Fully Populated board)
CH4 (POS) “Optional”	399-1610-F (RS-232 Fully Populated board)
CH5 (Dispenser)	499-2410 (Current loop board)
CH6 (Dispenser)	499-2410 (Current loop board)
CH7 (CAT/Cash).....	499-4710 (4 channel RS485 board)
CH9 (POS) “Optional”	399-1610-F (RS-232 Fully Populated board)
CH10 (POS) “Optional”	399-1610-F (RS-232 Fully Populated board)
CH11(POS) “Optional”	399-1610-F (RS-232 Fully Populated board)
CH12 (Sch/Tok PIC)	399-1610-F (RS-232 Fully Populated board)

* Up to 30 CATs may be connected to the SSC at channel 7. If Debit is required then only 29 CATs are supported because the MSM is configured as number 30.

2.2.3. SSC to Wayne Direct via the Wayne Data Box with the Helix PIC

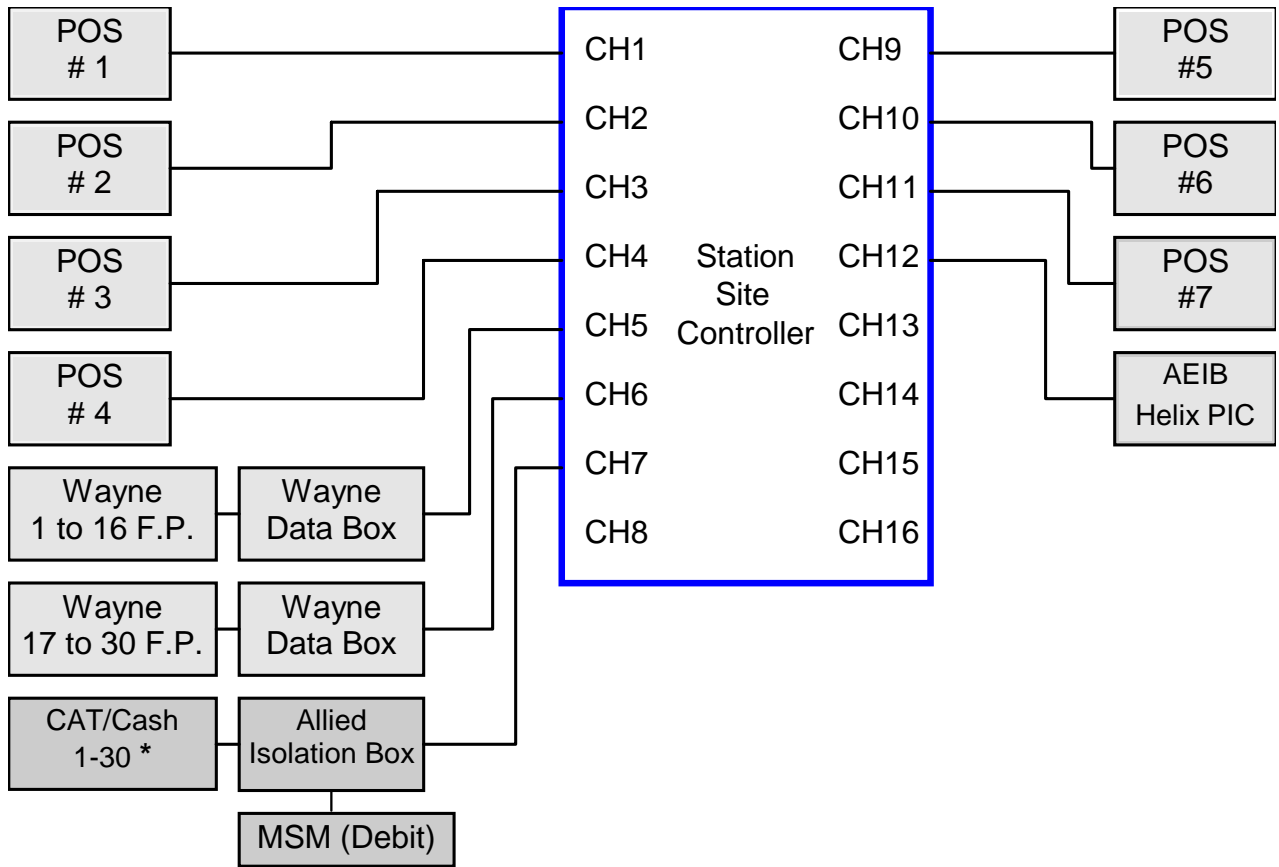

This figure describes an SSC to Wayne Direct with CAT installation.

Communication Boards

CH1 (POS)	399-1610-F (RS-232 Fully Populated board)
CH2 (POS) "Optional"	399-1610-F (RS-232 Fully Populated board)
CH3 (POS) "Optional"	399-1610-F (RS-232 Fully Populated board)
CH4 (POS) "Optional"	399-1610-F (RS-232 Fully Populated board)
CH5 (Dispenser)	499-2410 (Current loop board)
CH6 (Dispenser)	499-2410 (Current loop board)
CH7 (CAT/Cash).....	499-4710 (4 channel RS485 board)
CH9 (POS) "Optional"	399-1610-F (RS-232 Fully Populated board)
CH10 (POS) "Optional"	399-1610-F (RS-232 Fully Populated board)
CH11(POS) "Optional"	399-1610-F (RS-232 Fully Populated board)
CH12 (Allied Isolation Box/Helix PIC).....	499-4710 (4 channel RS485 board)

* Up to 30 CATs may be connected to the SSC at channel 7. If Debit is required then only 29 CATs are supported because the MSM is configured as number 30.

2.2.4. SSC to Wayne Direct via the Gilbarco “D” Box with the Helix PIC

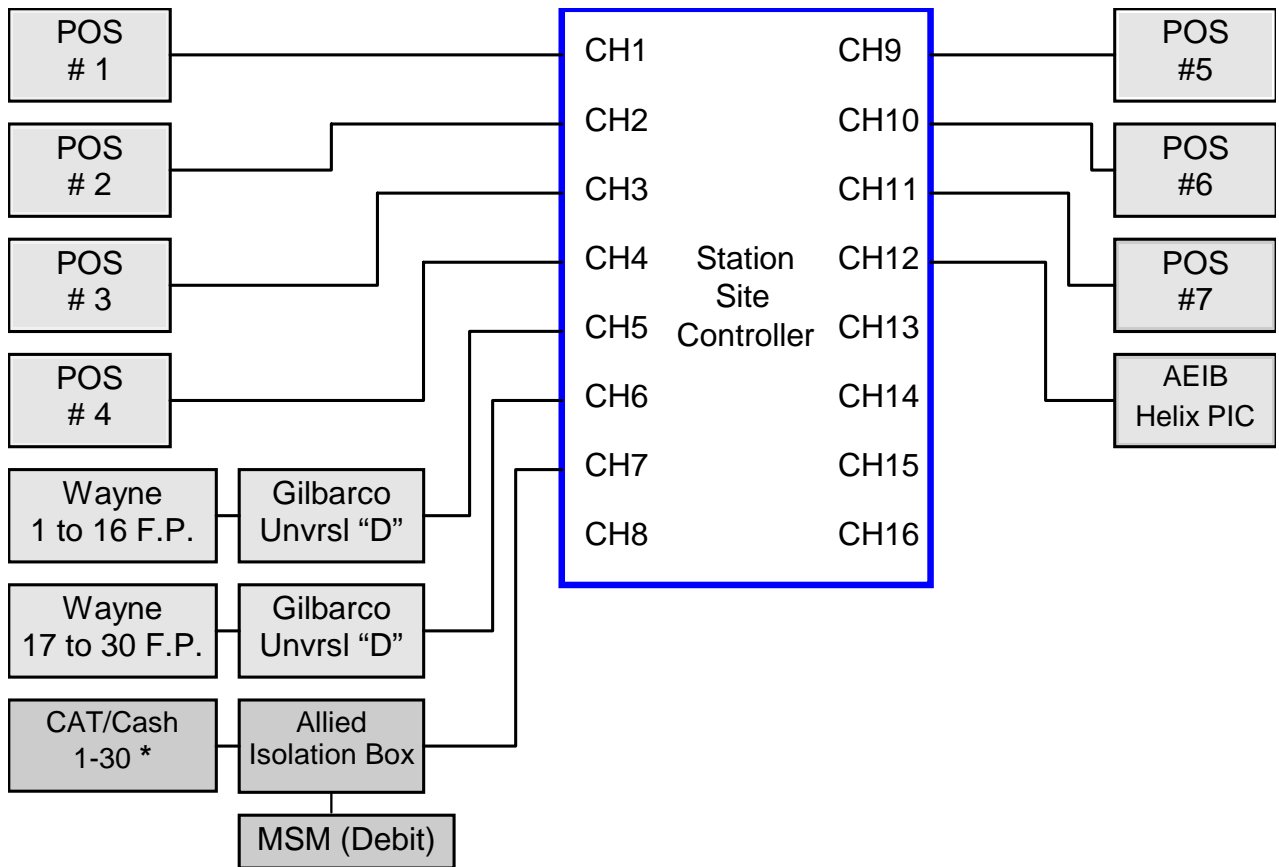

This figure describes an SSC to Wayne Direct via the Gilbarco “D” box with CATs.

Communication Boards

CH1 (POS)	399-1610-F (RS-232 Fully Populated board)
CH2 (POS) “Optional”	399-1610-F (RS-232 Fully Populated board)
CH3 (POS) “Optional”	399-1610-F (RS-232 Fully Populated board)
CH4 (POS) “Optional”	399-1610-F (RS-232 Fully Populated board)
CH5 (Dispenser)	499-2410 (Current loop board)
CH6 (Dispenser)	499-2410 (Current loop board)
CH7 (CAT/Cash).....	499-4710 (4 channel RS485 board)
CH9 (POS) “Optional”	399-1610-F (RS-232 Fully Populated board)
CH10 (POS) “Optional”	399-1610-F (RS-232 Fully Populated board)
CH11(POS) “Optional”	399-1610-F (RS-232 Fully Populated board)
CH12 (Allied Isolation Box/Helix PIC)...	499-4710 (4 channel RS485 board)

* Up to 30 CATs may be connected to the SSC at channel 7. If Debit is required then only 29 CATs are supported because the MSM is configured as number 30.

2.3. Cable Pin Assignments

2.3.1. POS Communication Cables

The SSC supports up to 7 POSs. The POS is a PC Based computer, which runs the Point-Of-Sale software. The serial port on the POS can be either a DB-25 or a DB-9 connector.

Note: The following cable configuration is being provided as an installation guide. Allied does not supply the POS cables with the ARCO ANDI/POS box.

SSC (CH1 - CH4 & CH9 - CH12) To POS (Serial Port) DB-25 Cable

SSC			POS		
DB25 Female			DB25 Female		
Pins			Pins		
TXD	2	-----	Black	-----	3 RXD
RXD	3	-----	White	-----	2 TXD
RTS	4	-----	Green	-----	5 CTS
CTS	5	-----	Red	-----	4 RTS
GND	7	-----	Blue	-----	7 GND
DSR	6	-----	Brown	-----	11 N/C
					20 DTR
DTR	11	-----	Orange	-----	6 DSR
N/C	20	-----		-----	

SSC (CH1 - CH4 & CH9 - CH12) To POS (Serial Port) DB-9 Cable

SSC			POS		
DB25 Female			DB9 Female		
Pins			Pins		
TXD	2	-----	Black	-----	2 RXD
RXD	3	-----	White	-----	3 TXD
RTS	4	-----	Red	-----	8 CTS
CTS	5	-----	Green	-----	7 RTS
DSR	6	-----	Brown	-----	4 DTR
GND	7	-----	Blue	-----	5 GND
DTR	11	-----	Orange	-----	6 DSR

2.3.2. Wayne Direct Dispenser Control Cable

The SSC uses a 45 ma current loop board to communicate to the Wayne dispensers. A total of 30 fueling positions may be connected to the SSC, up to 16 may be connected to channel 5 and up to 16 may be connected to channel 6. Channels 5 and or 6 must have a 2-wire custom cable or RJ45 adapter set that will be connected to either a Wayne Data Distribution box or a Gilbarco Universal "D" box.

2.3.2.1. Wayne Direct to the Wayne Data Distribution Box

SSC (CH5 or CH6) Wayne Direct Cable to the Wayne "D" box (Hard wired)

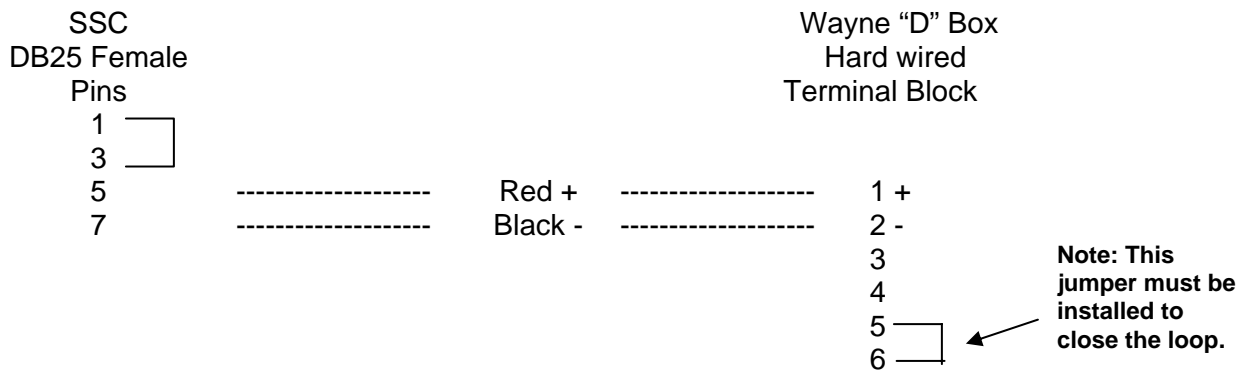

SSC (CH5 or CH6) Wayne Direct RJ45 adapter set to the Wayne "D" box

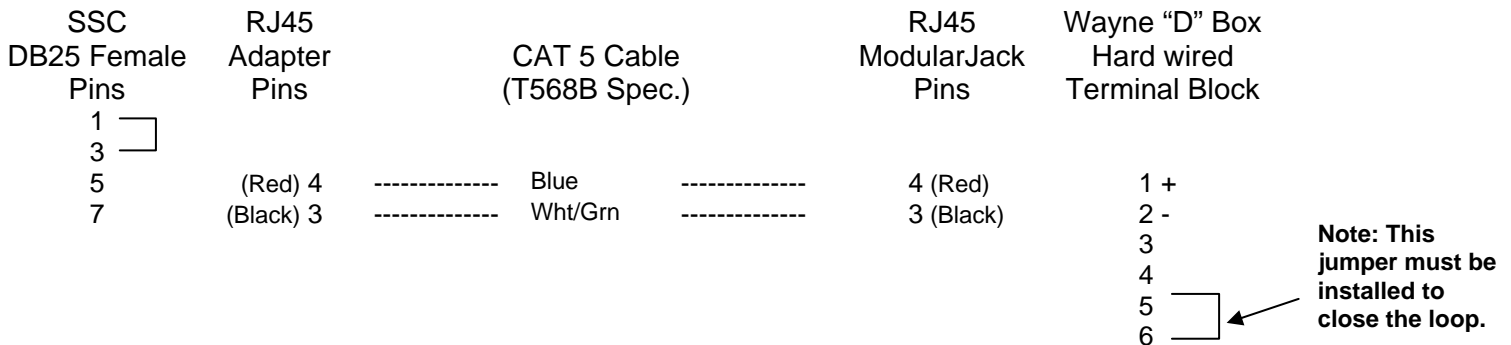

2.3.2.2. Wayne Direct to the Gilbarco Distribution Box

SSC (CH5 or CH6) Wayne Direct Cable to the Gilbarco “D” box (Female DB9)

SSC DB25 Female Pins				Gilbarco “D” box DB9 Female Pins	
1	□				
3					
5		-----	Red +	-----	7 +
7		-----	Black -	-----	6 -

SSC (CH5 or CH6) Wayne Direct Cable to the Gilbarco “D” box (RJ45)

SSC DB25 Female Pins				Gilbarco “D” box RJ45 ModularJack Pins	
1	□				
3					
5		-----	Brown +	-----	7 +
7		-----	Yellow -	-----	6 -

SSC (CH5 or CH6) Wayne Direct RJ45 adapter set to the Gilbarco “D” Box (DB9)

SSC DB25 Female Pins	RJ45 Adapter Pins		CAT 5 Cable (T568B Spec.)		RJ45 Adapter Pins	Gilbarco “D” Box (DB9)
1 □						
3 □						
5	(Red) 4	-----	Blue	-----	4 (Red)	7 +
7	(Black) 3	-----	Wht/Grn	-----	3 (Black)	6 -

SSC (CH5 or CH6) Wayne Direct RJ45 adapter set to the Gilbarco “D” Box (RJ45)

SSC DB25 Female Pins	RJ45 Adapter Pins		CAT 5 Cable (T568B Spec.)		Gilbarco “D” Box (RJ45)
1 □					
3 □					
5	(Brn) 7	-----	Wht/Brn	-----	7 +
7	(Yel) 6	-----	Green	-----	6 -

2.3.3. Wayne Direct CAT via the Allied Isolation Box

The SSC uses a 4-channel RS485 board to communicate to the Wayne CATs. Up to 30 CATs (**see note below**) may be connected to channel 7 of the SSC. Channel 7 must have an 8-wire RJ45 adapter that will be connected to the Allied Isolation box.

Note: Up to 30 CATs may be connected to the SSC at channel 7. If Debit is required then only 29 CATs are supported because the MSM is configured as number 30.

SSC (CH7) Wayne CAT RJ45 adapter set to the Allied Isolation box

SSC DB25 Female Pins	RJ45 Adapter Pins	CAT 5 Cable (T568B Spec.)	RJ45 Modular Jack Pins	Allied CAT Isolation Box
2	(Blu) 1	----- Wht/Org	1 (Blu)	1 RT1 +
3	(Org) 2	----- Orange	2 (Org)	2 RT1 -
6	(Blk) 3	----- Wht/Grn	3 (Blk)	3 RT2 +
7	(Yel) 6	----- Green	6 (Yel)	6 RT2 -
8	(Grn) 5	----- Wht/Blu	5 (Grn)	5 RT3 +
9	(Red) 4	----- Blue	4 (Red)	4 RT3 -
10	(Brn) 7	----- Wht/Brn	7 (Brn)	7 RT4 +
11	(Wht) 8	----- Brown	8 (Wht)	8 RT4 -

2.3.4. Wayne Direct CAT via a Junction box

The SSC uses a 4-channel RS485 board to communicate to the Wayne CATs. Up to 30 CATs ⁽¹⁾ may be connected to channel 7 of the SSC. Channel 7 must have an 8-wire RJ45 adapter that can be connected to a Junction box ⁽²⁾.

⁽¹⁾ Up to 30 CATs may be connected to the SSC at channel 7. If Debit is required then only 29 CATs are supported because the MSM is configured as number 30.

⁽²⁾ A plain Junction box can be used in order to connect the CAT communication wires to the RS485 wires that extend from the Modular Jack. In this configuration, up to 8 CATs can be hard wired to each of the four RS485 channels.

SSC (CH7) Wayne Direct CAT RJ45 adapter set to a Junction box

SSC DB25 Female Pins	RJ45 Adapter Pins	CAT 5 Cable (T568B Spec.)	RJ45 Modular Jack Pins	4" x 4" Junction Box Hard Wired	* This Junction box must be supplied by the installer.
2	(Blu) 1	----- Wht/Org	1 (Blu)	CH1 485 +	i h T h .
3	(Org) 2	----- Orange	2 (Org)	CH1 485 -	
6	(Blk) 3	----- Wht/Grn	3 (Blk)	CH2 485 +	
7	(Yel) 6	----- Green	6 (Yel)	CH2 485 -	
8	(Grn) 5	----- Wht/Blu	5 (Grn)	CH3 485 +	
9	(Red) 4	----- Blue	4 (Red)	CH3 485 -	
10	(Brn) 7	----- Wht/Brn	7 (Brn)	CH4 485 +	
11	(Wht) 8	----- Brown	8 (Wht)	CH4 485 -	

2.3.5. Schlumberger/Tokheim PIC via the (SAM/SSM)

The SSC uses channel 12 to interface to the SAM/SSM.

The SSM (Schlumberger Security Module) is required for the Payment Island Cashier (PIC) systems with debit and cash acceptor support.

Port 2 on the SAM/SSM has a Female DB-9 connector, which is to be connected to Channel 12 of the SSC. The cable pinouts are as follows:

SSC (CH12) To the SAM/SSM (Port 2)

SSC				SAM/SSM	
DB25 Female				DB-9 Male	
	Pins				Pins
Drain	1 -----	Shield	-----	N/C	
TXD	2 -----	White	-----	3	RXD
RXD	3 -----	Red	-----	2	TXD
GND	7 -----	Black	-----	7	GND
	4 <input type="checkbox"/>				
	5 <input type="checkbox"/>				
	6 <input type="checkbox"/>				
	11 <input type="checkbox"/>				

2.3.6. Helix PIC via the Allied Isolation Box

The SSC uses a 4-channel RS485 board to communicate to the Helix Pics. Up to 8 PICS (**see note below**) may be connected to channel 12 of the SSC. Channel 12 must be connected to J1 of the Allied Isolation box.

Note: Up to 8 PICS may be connected to the SSC at channel 12

SSC (CH12) Helix RJ45 adapter set to the Allied Isolation box

SSC DB25 Female Pins		CAT 5 Cable (T568B Spec.)		J1Allied Isolation Box
2	-----	Wht/Org	-----	1 RT1 +
3	-----	Orange	-----	2 RT1 -
6	-----	Wht/Grn	-----	3 RT2 +
7	-----	Green	-----	6 RT2 -
8	-----	Wht/Blu	-----	5 RT3 +
9	-----	Blue	-----	4 RT3 -
10	-----	Wht/Brn	-----	7 RT4 +
11	-----	Brown	-----	8 RT4 -

2.3.6.1. SSC/Helix to the Allied Isolation Box

Up to 8 HELIX/PICS may be connected to the Allied Isolation Box

SSC/Helix (CH7) To Allied Isolation box

SSC/Helix DB25 Female Pins				Allied Isolation box
1	-----	Shield	-----	Drain
2	-----	Red	-----	Data wire +
3	-----	Black	-----	Data wire -

Note: The SSC/Helix can communicate with dual or single sided Helix PICS.

Caution: The Helix cable cannot be installed in the same conduit as the intercom cable or high voltage lines. Serious damage to the Helix and or the SSC may result if the cable is not installed properly.

3. Programming

3.1. Wayne Direct Addressing

3.1.1. Wayne Direct Dispensers and CATs

Channels 5 and 6 have been designated to communicate to the Wayne dispensers (a maximum of 30 fueling positions). Each Channel can accommodate up to 16 fueling positions. The address of the first fueling position on Channel 5 will be set to address “1”, the second to address “2” etc. If channel 6 is used, the address of the first fueling position connected on this channel will be set to address “17”, the second to address “18” etc. See example.

Note: Up to 32 CATs may be connected to the SSC at channel 7. If Debit is required then only 29 CATs are supported because the MSM is configured as number 30.

Fueling Position		CAT	
Fueling Point	Address	SSC Channel	SSC Channel
1	1	CH-5	CH-7
2	2	CH-5	CH-7
3	3	CH-5	CH-7
4	4	CH-5	CH-7
5	5	CH-5	CH-7
6	6	CH-5	CH-7
7	7	CH-5	CH-7
8	8	CH-5	CH-7
9	9	CH-5	CH-7
10	10	CH-5	CH-7
11	11	CH-5	CH-7
12	12	CH-5	CH-7
13	13	CH-5	CH-7
14	14	CH-5	CH-7
15	15	CH-5	CH-7
16	16	CH-5	CH-7
17	17	CH-6	CH-7
18	18	CH-6	CH-7
19	19	CH-6	CH-7
20	20	CH-6	CH-7
21	21	CH-6	CH-7
22	22	CH-6	CH-7
23	23	CH-6	CH-7
24	24	CH-6	CH-7
25	25	CH-6	CH-7
26	26	CH-6	CH-7
27	27	CH-6	CH-7
28	28	CH-6	CH-7
29	29	CH-6	CH-7
30	30	CH-6	CH-7

3.1.2. Wayne “Vista” Dispensers

The following parameters must be set in the Wayne “Vista” dispensers in order for the system to function correctly.

Vista Dispenser		
Model	Option #2 (Macro)	Option #51 (Blend Ratios)
V390 D1, (<i>non-blend</i>)	5	N/A
V395 D1, (<i>variable blend</i>)	13	Must match Point Of Sale
V580 D1, (<i>variable blend</i>)	10	Must match Point Of Sale
V580 D3, (<i>variable blend</i>)	11	Must match Point Of Sale
V590 Uni-hose, (<i>fixed blend</i>)	10	Must match Point Of Sale
V590 D1, (<i>fixed blend</i>)	7	Must match Point Of Sale

3.1.3. Wayne “Vista” Blending Dispensers

Variable Blenders

The ANDI interfaces to the following Wayne variable blenders.

- 580 D1** - Single hose. Multi product dispenser without diesel.
- 580 D3** - Single hose. Multi product dispenser without diesel.
- 395** - Single hose + 1. Multi product dispenser with diesel.

Fixed Blenders

The ANDI interfaces to the following Wayne fixed blenders.

- 590** - Multi hose, multi product dispenser without diesel.
- 590U** - Single hose, multi product dispenser without diesel. Uses the same configuration as the 580.

Dispenser and POS Settings

For the Wayne blenders to operate properly, several options must be set at the dispenser and also at the POS.

Dispenser Macro

The dispenser options are set via a macro. Below are the proper macro settings for the variable blenders.

Model Type	Macro Setting
590	7
395	13
580 D1 & 590U	10
580 D3	11

Note: The blend ratio that is set at the POS must match option 51 in the dispenser.

POS Product to Position Mapping

The following is a list of the Wayne product identification numbers:

- 1- Diesel
- 2- Not Used
- 3- Mid grade, ***Non Blended Product***
- 4- Low grade
- 5- High grade
- 6- Blended product

The POS fuel product I.D. numbers must match the Wayne product I.D. numbers. If the product I.D. numbers do not match and if there is a card reader at the dispenser the card reader will display ***“Dispenser Unavailable”***, after configuration. Once the product mapping is corrected, the dispenser card reader will display the idle prompt.

The tables below list the proper fueling point ***“product to position”*** assignment for each blender type. This programming is done via the ***Fueling Point Configuration Menu*** at the POS.

The ***blender type*** setting is not used and should be set to zero (0).

Model 590

Position	Product
1	Not assigned
2	Low grade
3	Blended product
4	High grade
5	Not assigned
6	Not assigned
7	Not assigned
8	Not assigned

**** The low grade and the high grade products may be switched depending on the position of the dispenser and the installation of the product lines.***

The **blender type** setting is not used and should be set to zero (0).

Model 395

Position	Product
1	Diesel
2	Not assigned
3	Not assigned
4	High grade
5	Blended product
6	Low grade
7	Not assigned
8	Not assigned

** The low grade and the high grade products may be switched depending on the position of the dispenser and the installation of the product lines.*

The **blender type** setting is not used and should be set to zero (0).

Models 580 D1 & 590 U

Position	Product
1	Not assigned
2	Not assigned
3	High grade
4	Not assigned
5	Blended product
6	Not assigned
7	Low grade
8	Not assigned

** The low grade and the high grade products may be switched depending on the position of the dispenser and the installation of the product lines.*

The **blender type** setting is not used and should be set to zero (0).

Model 580 D3

Position	Product
1	Not assigned
2	Not assigned
3	High grade
4	Blended product
5	Low grade
6	Not assigned
7	Not assigned
8	Not assigned

** The low grade and the high grade products may be switched depending on the position of the dispenser and the installation of the product lines.*

3.1.4. Wayne Blending Quick Reference Guide

Dispenser Model	Dispenser Macro	POS FP Positions
395	13	1- Diesel 2- Not Assigned 3- Not Assigned 4- High grade 5- Blend grade 6- Low grade 7- Not Assigned 8- Not Assigned
580 D1 & 590 U	10	1- Not Assigned 2- Not Assigned 3- High grade 4- Not Assigned 5- Blend grade 6- Not Assigned 7- Low grade 8- Not Assigned
580 D3	11	1- Not Assigned 2- Not Assigned 3- High grade 4- Blend grade 5- Low grade 6-Not Assigned 7-Not Assigned 8- Not Assigned
590	07	1- Not Assigned 2- Low grade 3- Blend grade 4- High grade 5- Not Assigned 6- Not Assigned 7- Not Assigned 8- Not Assigned

Note: "Not Assigned" = 0 product value.

3.2. PIC Addressing (Payment Island Cashier)

3.2.1. Schlumberger/Tokheim PIC

Channel 12 of the ANDI box has been designated to communicate with the Schlumberger/Tokheim PICs (via the SAM). Each PIC can be configured (via the POS) to control any or all of the fueling positions. The PICs can be addressed from 1-8. (See *example*)

3.2.1.1. Schlum/Tok Access/Security Module (SAM/SSM) for Debit

The Schlumberger/Tokheim Access/Security Module (SAM/SSM) must be ordered from Schlumberger for a specific Network application. The following switches in the SAM/SSM must be set for proper operation.

SAM/SSM Switch #1		SAM/SSM Switch #3	
Position	Setting	Position	Setting
1	off	1	off
2	on - DUKPT off - MK/SK	2	on
3	off	3	off
4	off	4	on
5	on	5	off
6	off	6	on
7	off		
8	on		

Example:

PIC Address	SSC Channel
1	CH-12
2	CH-12
3	CH-12
4	CH-12
5	CH-12
6	CH-12
7	CH-12
8	CH-12

3.2.2. Helix PIC

Channel 12 of the ANDI box has been designated to communicate with the Helix PICs (Via the Allied Isolation box). Each PIC can be configured (via the POS) to control any or all of the fueling positions. The PICs can be addressed from 1-8. (See *example*)

Note: The Helix PIC IDs must also be setup thru the keypad on the PIC itself.

Example:

PIC Address	SSC Channel
1	CH-12
2	CH-12
3	CH-12
4	CH-12
5	CH-12
6	CH-12
7	CH-12
8	CH-12

3.3. SSC Parameters Values and Options

The SSC keypad is not used to configure the SSC. The SSC configuration is done by the POS. The POS has to download all required parameters to the SSC. The SSC will start polling the dispensers only after the POS has downloaded station configuration data. If the SSC has not receive the download from the POS you will see [CHXX Await Cnfg.] This means the SSC is waiting to be configured before this Channel becomes active.

Parameters Downloaded from POS:

- DPT and PIC Configuration
- Fuel Information
- Product Information
- Cash / Credit Limits
- Mode of Service
- Default Price Level
- Sale Stacking
- Number of fueling positions

3.4. Keypads

3.4.1. Wayne

Type 1

1	2	3		Pay Outside Credit
4	5	6	Pay Inside Cash	Pay Inside Credit
7	8	9	No	Yes
Clear	0	Enter	Help	Cancel

Type 2

1	2	3		Pay Outside
4	5	6		Pay Inside
7	8	9	No	Yes
Clear	0	Enter	Help	Cancel

Type 3

1	2	3	Pay Outside Debit	Pay Outside Credit
4	5	6	Pay Inside Cash	Pay Inside Credit
7	8	9	No	Yes
Clear	0	Enter	Help	Cancel

Type 4

1	2	3	Pay Inside	Pay Outside
4	5	6		
7	8	9	No	Yes
Clear	0	Enter	Help	Cancel

Type 6

1	2	3	Yes
4	5	6	No
7	8	9	Help
Clear	0	Enter	Cancel

Type 7

1	2	3	Yes
4	5	6	No
7	8	9	
Clear	0	Enter	Cancel

Type 8

1	2	3	Yes
4	5	6	No
7	8	9	Help
Clear	0	Cancel	Enter

Type 9

1	2	3		
4	5	6		
7	8	9	Yes	Help
Clear	0	Enter	No	Cancel

Type A

1	2	3		Pay Outside Credit
4	5	6		Pay Inside
7	8	9	No	Yes
Clear	0	Enter	Help	Cancel

Type B

1	2	3	Pay Outside Debit	Pay Outside Credit
4	5	6		Pay Inside
7	8	9	No	Yes
Clear	0	Enter	Help	Cancel

Type C

1	2	3		Pay Outside Credit
4	5	6	Pay Outside Cash	Pay Inside
7	8	9	No	Yes
Clear	0	Enter	Help	Cancel

Type D

1	2	3	Pay Outside Debit	Pay Outside Credit
4	5	6	Pay Outside Cash	Pay Inside
7	8	9	No	Yes
Clear	0	Enter	Help	Cancel

Type E

1	2	3	Yes
4	5	6	No
7	8	9	Help
Clear	0	Enter	Cancel

Type F

1	2	3	Yes
4	5	6	No
7	8	9	Cancel
Clear	0	Enter	Debit

Type G

1	2	3	Pay Inside	
4	5	6	Pay Outside Credit	Pay Outside Debit
7	8	9	Help	Cancel
Clear	0	Enter	Yes	No

Type H

1	2	3	Credit	
4	5	6	Debit	
7	8	9	No	Yes
Clear	0	Enter	Help	Clear/Cancel

Type I (FCL)

1	2	3	Yes	French
4	5	6	No	
7	8	9	Help	
Clear	0	Enter	Cancel	

Type J

1	2	3	Pay Outside	
4	5	6	Pay Inside	
7	8	9	Yes	Help
Clear	0	Enter	No	Cancel

3.4.2. Schlumberger PIC

Enter	1	2	3
Receipt	4	5	6
English Espanol	7	8	9
Cancel	Clear	0	

3.5. Peripheral Devices

3.5.1. Tank Gauge Systems

The ANDI/SSC uses Channel 13 to interface to either the Veeder-Root tank gauge system or the Red Jacket "ST Model" tank gauge system. The SSC is connected to the Serial board on a Device and it may be connected to the DIM board on a TLS 350R.

When the SSC is connected to the DIM board on a TLS 350R it will send real-time fuel transaction data i.e. sale started, sale complete, volume dispensed, meter reading etc. This is accomplished by implementing the Veeder-Root Dispenser Interface Protocol (a proprietary interface defined by Veeder-Root. to the TLS 350R). This will allow the TLS to utilize the AccuChart Automatic Tank Calibration feature for underground storage tank reconciliation.

Configure the TLS-250/350/350R or the Red Jacket communication parameters as follows:

Baud Rate - 9600, Parity - Odd, Stop Bits - 1, Data Bits - 7

Notes:

On a TLS-250 the communication parameters are set using a rotary switch and some DIP switches, (please refer to the TLS 250 manual).

On a TLS-350/350R the communication parameters are programmed via the TLS keyboard (please refer to the TLS 350/350R manual).

No additional SSC configuration is needed, the SSC will automatically check if it is connected to a DIM card. If not, the SSC will not send any Dispenser Interface commands to the TLS. Communicating with other devices requires POS programming.

To display the TLS link status press the "D" key on the SSC keyboard.

CH-13 Link Up
TLS RS-232 FP

Once the SSC detects it is connected to a DIM board the device name changes to TLS-R

CH-13 Link Up
TLS-R RS-232 FP